

Iliffe Electrical Publications Ltd.,
Dorset House, Stamford Street,
London, S.E.1

Managing Director:

W. E. MILLER, M.A., M.I.E.R.E.

Editor:

F. L. DEVEREUX, B.Sc.

Assistant Editors:

H. W. BARNARD

T. E. IVALL

Editorial

D. C. ROLFE

G. B. SHORTER, B.Sc.

Drawing Office:

H. J. COOKE

Production:

D. R. BRAY

Advertisements:

G. BENTON ROWELL
(Manager)

J. R. EYTON-JONES

Please address to Editor, Advertisement
Manager or Publisher as appropriate

© Iliffe Electrical Publications
Ltd., 1965. Permission in writing
from the Editor must first be
obtained before letterpress or
illustrations are reproduced from
this journal. Brief extracts or
comments are allowed provided
acknowledgement to the journal
is given.

VOLUME 71 No. 1

PRICE: 3s 0d.

FIFTY-FOURTH YEAR
OF PUBLICATION

Wireless World

ELECTRONICS, TELEVISION, RADIO, AUDIO

JANUARY 1965

- 1 Editorial Comment
- 2 Transistor High-quality Audio Amplifier *By J. Dinsdale*
- 10 Electronic Laboratory Instrument Practice—1 *By T. D. Towers*
- 16 Recent Technical Developments
- 17 Oscar III *By W. H. Allen*
- 18 Miniature Selenium Rectifiers for Television E.H.T. *By J. L. Storr-Best*
- 24 Monostable Blocking Oscillator *By M. D. A. B. Rackowe*
- 26 Units *By "Cathode Ray"*
- 28 H.F. Predictions—January
- 29 World of Wireless
- 31 Personalities
- 33 Conferences and Exhibitions
- 34 Books Received
- 35 Manufacturers' Products
- 41 Letters to the Editor
- 44 Logic Without Tears *By H. R. Henly*
- 50 Commercial Literature
- 51 "Chorus" *By M. Lorant*
- 53 January Meetings
- 54 News from Industry
- 56 Real and Imaginary *By "Vector"*

PUBLISHED MONTHLY (4th Monday of preceding month). Telephone: Waterloo 3333
(70 lines). Telegrams: "Ethaworld, London Telex." Cables: "Ethaworld, London, S.E.1."
Annual Subscriptions: Home £2 0s 0d. Overseas £2 5s 0d. Canada and U.S.A. \$6.50. Second-class
mail privileges authorised at New York N.Y. BRANCH OFFICES: BIRMINGHAM: King
Edward House, New Street, 2. Telephone: Midland 7191. BRISTOL: 11, Marsh Street, 1.
Telephone: Bristol 21491/2. COVENTRY: 8-10, Corporation Street. Telephone: Coventry
25210. GLASGOW: 123, Hope Street, C.2. Telephone: Central 1265-6. MANCHESTER:
260, Deansgate, 3. Telephone: Blackfriars 4412. NEW YORK OFFICE U.S.A.: 111,
Broadway, 6. Telephone: Digby 9-1197.

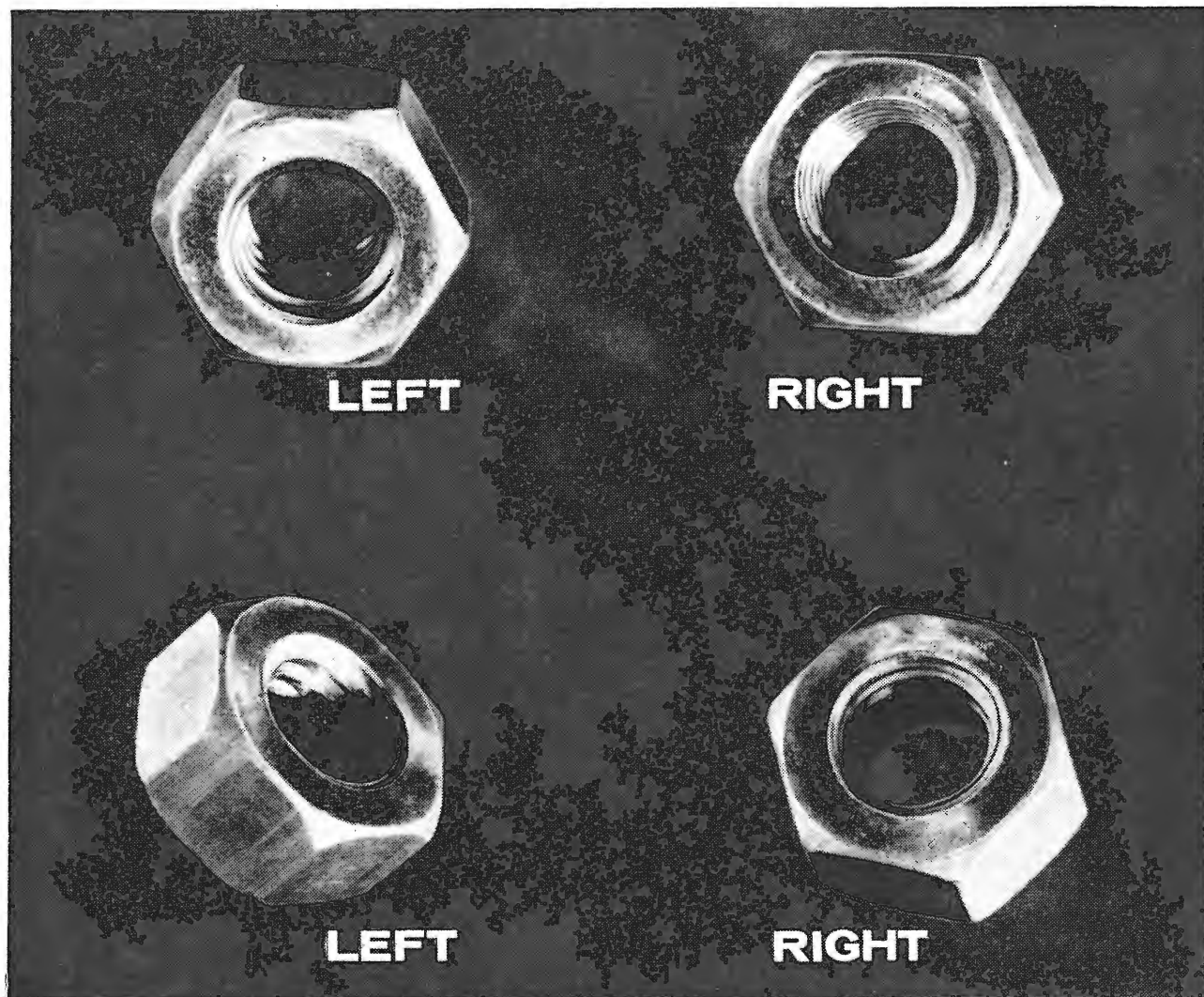

TV SERVICING'S

NEW

You can forget about old-style servicing. The independently mounted 'Panorama' direct vision tube can be fixed or unfixed in minutes. It's as simple as four nuts.

MARCHING ORDERS

One for each of the Panorama's four conveniently positioned mounting lugs. Left, right, left, right. Servicing was never easier. For the first time ever you can forget about dust seals and mounting accessories. And remember, 'Panorama' direct vision introduces: * sharper, brighter pictures with no dust or multiple reflections. * truer picture realism thanks to elimination of protective screen. * new freedom in TV styling.

Mullard

PANORAMA PICTURE TUBES

1WW-116 FOR FURTHER DETAILS.

www.americanradiohistory.com

Wireless World

ELECTRONICS, TELEVISION, RADIO, AUDIO

Dissemination and Retrieval of Information

AMONG the research projects put forward by the National Electronics Research Council, high priority has been given to the retrieval of information. Lord Mountbatten, in his speech last autumn to the Conference of the Electronics Industry, was able to announce the appointment of a full-time qualified specialist to work with the N.E.R.C. Committee on the scientific Dissemination of Information. Of the new venture he had this to say:—

“Our system will use a computer to select from the hundreds of papers and articles published every week the references to those of interest to each particular research worker throughout the country. It will incorporate a feedback loop to allow changes in the interests of each research worker to be embodied in the system. In addition to separate lists for each research worker, a weekly listing of all new material will be provided and there will be facilities for retrospective searching by computer. This project can, of course, be developed to serve all branches of science and industry. We believe it will take about three years to develop this project to the full and we hope to make a major breakthrough in tackling the information explosion problem.”

This project, when completed, will bear comparison in scale with similar work in America and Russia and will powerfully supplement, if it does not supersede, other systems for running down the facts needed. It will not, however, solve the problems of deciding what is to go into the stores (we use the plural advisedly) or what to do with the jackpot when any particular button is pressed.

If the solution to the first problem is to include everything, does that mean also the commercial and military secrets of industry and Government? Obviously there must be selection and segregation, which raises the question of who is to make the final choice. The process of filtration begins earlier when the author commits his thoughts to paper. It is continued by his employer before giving permission to publish, then by the editor of a journal or the referees of a learned society and finally by indexers, librarians, data processors and the custodians of computers. But what of the many papers which are never published? Should not these rejects be systematized also, if only to give someone the opportunity of discovering a latter-day F. W. Lanchester or O. Heaviside?

With the enormous bulk of material to be handled there may be a temptation to rely on titles and synopses. We hope that indexers will find time to read more deeply. Authors' titles are often changed, sometimes to reduce them to manageable length, quite often to enhance what the editor regards as the main interest of the contents. How is an editor or an indexer to know that the future value of a paper on, say, the neurophysiology of the cochlea of the cat may rest on a new technique of d.c. amplification which was used to obtain the results? Values change and any system of selection and indexing must be capable of constant revision.

The growth and decline of value affects also the processes of retrieval. At the frontiers of knowledge where the need is greatest, one cannot afford to take chances. The jackpot must contain everything. The coinage will be strange and only time will show what is sound and what spurious. Hence the need for constant re-assessment and the removal (not the rejection) of “rubbish” to another bin.

We hope that the system of retrieval which finally emerges will permit access at different levels as well as at vertical divisions of subject. At the foundation would be found the classical text-books; above these the co-ordinating papers which acknowledged authorities should feel it their duty to write from time to time; still higher those papers which statistical analysis shows to have appeared frequently in bibliographies; and above all the uncondensed froth of current literature.

Computers will have their place in converting data into information, but the process of turning information into knowledge and ultimately into understanding is essentially a human problem involving consensus of opinion based on individual effort and choice.

Stereo/Mono Integrated Version, Mk II

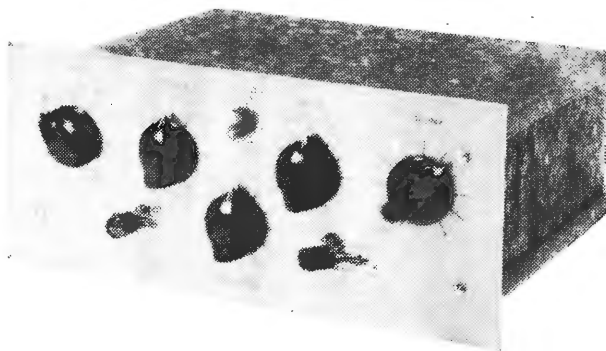

TRANSISTOR HIGH-QUALITY AUDIO AMPLIFIER

By J. DINSDALE,* M.A.

SINCE the publication three years ago of articles describing a transistorized high-quality amplifier¹ and pre-amplifier,² prolonged listening tests and series of measurements have been conducted both on this design and on several commercial systems which are becoming available. In addition, I have received a wealth of constructive comment (and criticism) from colleagues and readers of *Wireless World*, many of whom bear out my own feelings. The appearance, moreover, of several articles on transistor amplifiers, notably by P. Tharma, T. D. Towers and the series by O. Greiter, show that the trend to transistor units has become firmly established. In short, I believe that the time has arrived to examine in greater detail some aspects of the original design and to describe some modifications which may be made to improve the performance.

General Specification

It was decided to maintain the basic specification of the original amplifier and follow normal commercial figures as far as possible. Thus the input sensitivities are 4 mV for magnetic pickups and 400 mV for crystal pickups. The "auxiliary" input may be used for radio tuner (80 mV) microphone (5 mV) or tape head (3 mV).

Treble and bass controls are provided, together with a switched low-pass filter and an improved infinitely variable balance control. The use of low-noise transistors maintains a satisfactory background level even at full volume. The input level to the power amplifier is 100 mV for 10 watts output, and the frequency response of the complete system is flat within 2 dB from 35 c/s to 20 kc/s, with a total harmonic distortion of under 0.2% at 10 watts.

Input Impedance

It was stated in the original article (and has been reiterated more recently) that the most efficient way of designing pre-amplifiers for low sensitivity magnetic pickups and tape replay heads is to work into a low-impedance load and utilize the inductance of the trans-

ducer in series with this low impedance to achieve the h.f. de-emphasis in the replay characteristics, as shown in Fig. 1. The advantages claimed for this mode of operation are twofold.

(i) The transistor is a current-operated device and therefore a low-impedance source will raise the sensitivity of the input stage and hence that of the pre-amplifier.

(ii) The noise generated in the input transistor may

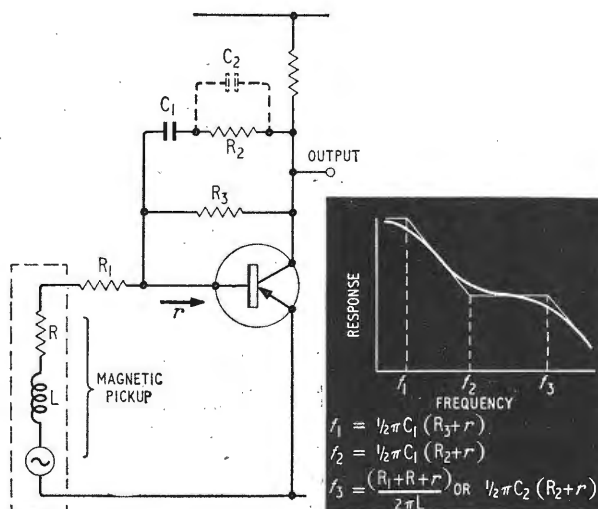

Fig. 1. Method used in the original (1961) design for equalization of magnetic pickups. C_2 is used only when R_1 is large enough to remove the effect of L from the audio spectrum.

be minimized by connecting the base to ground via a low-impedance (e.g., the pickup). Unfortunately there are certain side effects which detract from the apparent

* Elliott Brothers (London) Ltd.

advantages of this system and, indeed, when a stereo pickup is used, can become most undesirable.

For example, one of the main problems in the design of stereophonic pickup heads is to reduce crosstalk between channels to a satisfactory level (better than 20dB) over the full frequency range, but especially above 2kc/s, where most of the directional information is found. While this figure may be approached in the modern high-quality instrument, it will only apply when the currents flowing in the component coils are negligible, for two reasons.

(i) The magnetic field set up by the current will be sufficient to cause a reduction in channel separation due to the proximity of the coils in the confined space available inside the head causing direct transformer coupling between channels.

(ii) A more serious effect occurs with the sum-and-difference type of pickup (e.g. the Decca "ffss" and E.M.I. EPU100) where a common coil carries the lateral signal before being combined with each phase of the vertical signal to form the complete output. Both left- and right-hand currents flow in the common lateral coil and owing to the impedance of this coil (2 to 12kΩ depending on the frequency) considerable crosstalk will result. Indeed the Decca "ffss" Mk. I head and Decca Stereo test record SXL 2057 produced 2 kc/s signals in each channel of the original pre-amplifier of only 6 dB difference, although only one channel contained recorded information. An analysis is given in the Appendix.

A further practical difficulty concerns the use of pickups with widely differing inductances (as may happen for example in demonstrations and tests). It is inconvenient to change the input resistor continually and, moreover, there comes a time when the inductance of a particular pickup is so low that even without any series resistor the input impedance of the transistor is itself too high to

TABLE I—COMPONENT VALUES FOR FIG. 2

R1	100kΩ	2%, high stability	R17	8.2kΩ	2%, high stability
R2	68kΩ	2%, high stability	R18	56kΩ	2%, high stability
R3	100kΩ	2%, high stability	R19	10kΩ	
R4	82kΩ	2%, high stability	R20	8.2kΩ	2%, high stability
R5	10kΩ	2%, high stability	R21	15kΩ	2%, high stability
R6	12kΩ		R22	3.3kΩ	
R7	12kΩ		R23	3.3kΩ	
R8	22kΩ		R24	2.7kΩ	
R9	5.6kΩ		R25	2.7kΩ	
R10	1.2kΩ		R26	2.2kΩ	
R11	10kΩ		R27	6.8kΩ	
R12	4.7kΩ		R28	33kΩ	
R13	470Ω		R29	2.2kΩ	
R14	1.8kΩ		R30	2.2kΩ	
R15	180kΩ	2%, high stability	R31	1kΩ	
R16	15kΩ	2%, high stability	R32	10kΩ	If used with 40-volt supply.

All resistors ½ watt, and 5% unless otherwise stated.

C1	200μF	6V wkg. electrolytic	C14	0.12μF	5%
C2	10μF	6V wkg. electrolytic	C15	0.01μF	5%
C3	50μF	6V wkg. electrolytic	C16	0.0068μF	5%
C4	50μF	6V wkg. electrolytic	C17	0.1μF	5%
C5	10μF	6V wkg. electrolytic	C18	25μF	15V.W. electrolytic
C6	100μF	6V wkg. electrolytic	C19	0.0033μF	5%
C7	0.0047μF	5%	C20	0.01μF	5%
C8	0.015μF	5%	C21	100μF	6V.W. electrolytic
C9	0.0068μF	5%	C22	0.001μF	5%
C10	0.047μF	5%	C23	0.0047μF	5%
C11	0.0047μF	5%	C24	0.01μF	5%
C12	10μF	15V.W. electrolytic	C25	10μF	6V.W. electrolytic
C13	50μF	20V.W. electrolytic	C26	50μF	20V.W. electrolytic

In the prototype the small electrolytics used were Wima "Printlyt", or Plessey miniature (not subminiature), larger (1000μF+), Plessey "CE", and other capacitors Mullard Polyester 125V.

RV1	Bass	50kΩ + 50kΩ linear	} Morganite Type AG
RV2	Treble	25kΩ + 25kΩ linear	
RV3	Balance	10kΩ log. + 10kΩ, antilog.	
RV4	Volume	10kΩ + 10kΩ, log	

S1	Input	4-pole 5-way (2-bank)	Model DH, NSF
S2	Filter	2-pole 3-way	Model TG, NSF
S3	Function	3-pole 3-way	Model TG, NSF

Vt 1, 2, 3. OC44, OC75, AC107, GET880, etc. ($h_{fe} > 60$ at $I_0 = 1$ mA.)

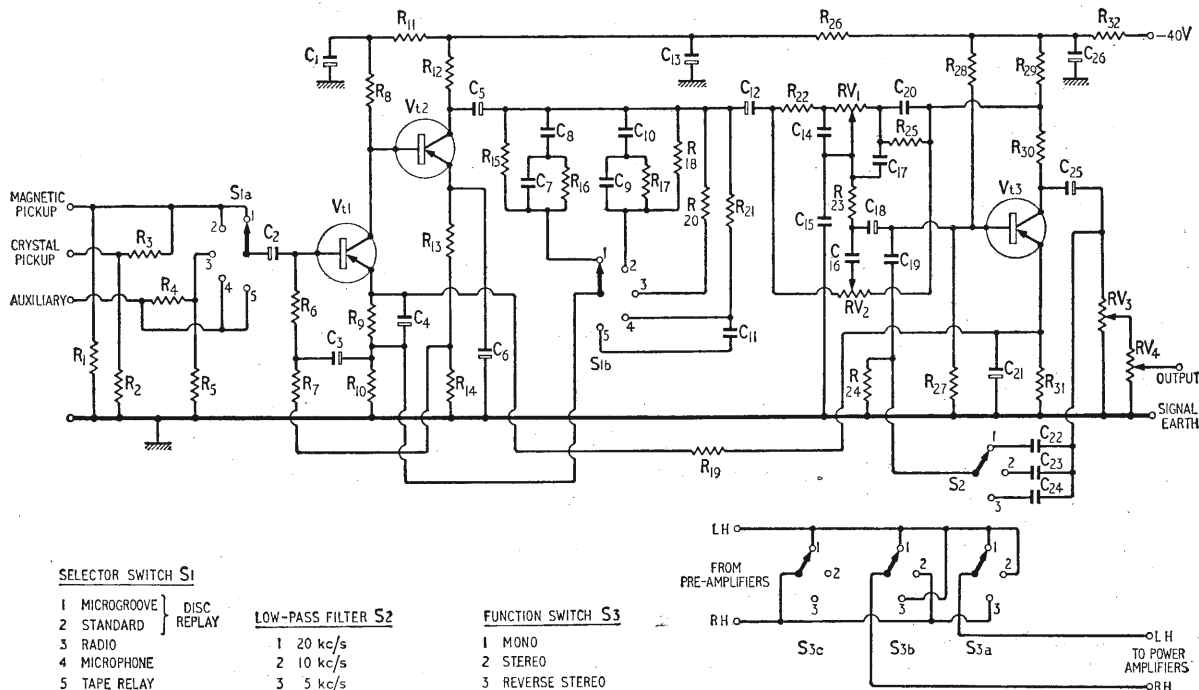

Fig. 2. Circuit of revised pre-amplifier with high input impedance.

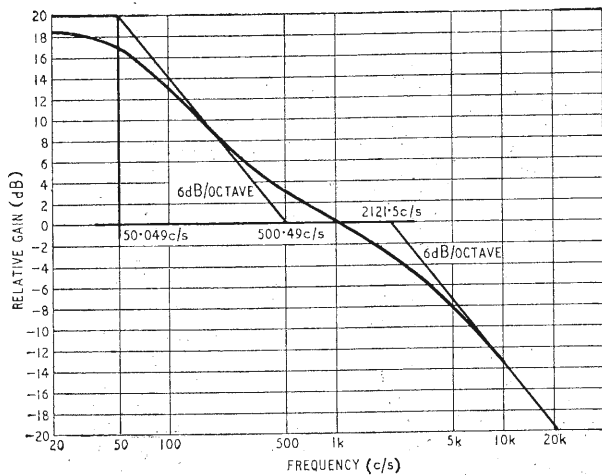

Fig. 3. R.I.A.A. microgroove characteristic.

allow for accurate equalization. This also raises another point: that one should not be forced to rely on the inductance of a particular manufacturer's device being maintained to close limits over a prolonged period of production. All the above stresses the need for an input impedance high enough to keep the accompanying L/R roll-off well outside the audio band, provided that the noise figure does not rise unduly. Equalization for the recording characteristic may then be achieved by conventional feedback networks.

Revised Pre-amplifier

The new pre-amplifier circuit Fig. 2 follows the basic form of the original, but with a completely new input stage. Two transistors are used in this stage with heavy a.c. feedback via C_3 and R_6 . This has the effect of increasing the input impedance at the base of Vt1 to about 500k Ω , while at the same time keeping noise to a minimum since the base of Vt1 can still be loaded to ground via the impedance of the transducer. (This, of course, would not happen if the problem of raising the input impedance had been solved merely by adding a suitable series input resistor and increasing the sensitivity.) Since the actual impedance is frequency-dependent and is in any case far higher than is normally required, a padding resistance has been incorporated in each input network to stabilize the value over the audio band.

Equalization is again performed by feedback, but taken

Fig. 4. Feedback network for R.I.A.A. disc equalization.

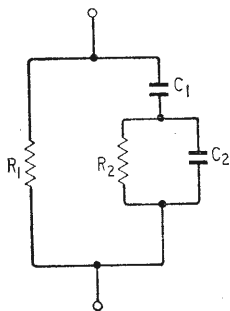

33 $\frac{1}{3}$ AND 45 r.p.m.		78 r.p.m.	
$C_1 R_1 = 2,940$	$C_1 R_1 = 2,780$	$C_1 R_1 = 2,780$	$C_1 R_1 = 2,780$
$C_2 R_2 = 81.2$	$C_2 R_2 = 57.3$	$C_2 R_2 = 57.3$	$C_2 R_2 = 57.3$
$\frac{R_1}{R_2} = 12.4$	$\frac{R_1}{R_2} = 7.08$	$\frac{R_1}{R_2} = 7.08$	$\frac{R_1}{R_2} = 7.08$
(C IN MICROFARADS, R IN OHMS)			

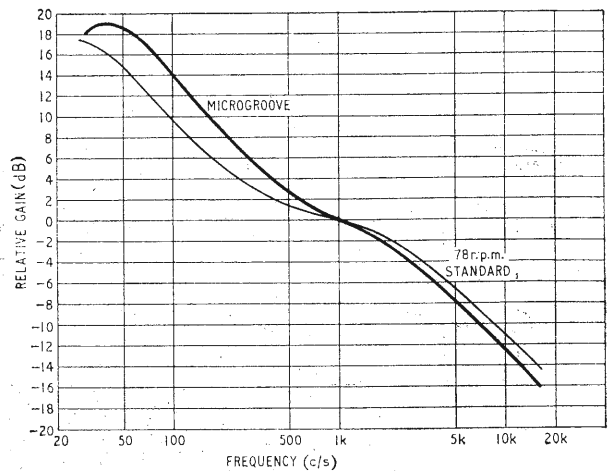

Fig. 5. Disc replay response curves.

this time from the collector of Vt2 to *emitter* of Vt1, since the first stage is no longer a virtual-earth amplifier with an input impedance of effectively zero, and any feedback from the collector of Vt2 to the *base* of Vt1 would reduce the high input impedance.

This first stage has a voltage gain of approximately 10 in its most sensitive mode (microphone and magnetic pickup inputs) and is followed by the output stage consisting of a single transistor Vt3. This stage is very similar to the original article, and incorporates negative feedback tone controls and low-pass filters. Overall negative feedback from the emitter of Vt3 via R_{11} provides additional stability at very low frequencies.

Magnetic Pickup Input

Since all pickups operating on the electromagnetic principle have a velocity characteristic, i.e. the output is proportional to the velocity of the stylus, the output will be identical to the recording characteristic and equalization is necessary. It was decided to provide equalization to the RIAA specification for both microgroove and standard recordings, since this has been the International Standard since 1955. The microgroove characteristic is detailed in Fig. 3, and the calculated turnover frequencies occur at 50.049c/s, 500.49c/s and 2121.5c/s. The characteristic may be achieved by three separate networks with a buffer stage between each to prevent interaction, but if, as in most applications, a single network is to be used, the parameters are as shown in Fig. 4. A convenient way of determining the component values is to choose R_2 to provide the required sensitivity and then calculate the remaining values. Thus in the present design if $R_2 = 15k\Omega$, for microgroove,

$R_1 = 186 k\Omega$ (omitted since its effect is negligible[†])

$C_1 = 16,300 pF$, nearest value 15,000 pF

$C_2 = 5,400 pF$, nearest value 4,700 pF

Similarly if $R_2 = 8.2 k\Omega$ for 78 r.p.m. standard discs,

$R_1 = 58 k\Omega$ (omitted)[†]

$C_1 = 48,000 pF$, nearest value 47,000 pF

$C_2 = 7,000 pF$, nearest value 6,800 pF

In the prototype, the above values were found to give

[†] These resistors will, in fact, reduce the response by about 1dB at 50c/s, and provision for fitting them if desired has been made on the printed circuit. The curves in Fig. 5 were measured *without* these resistors.

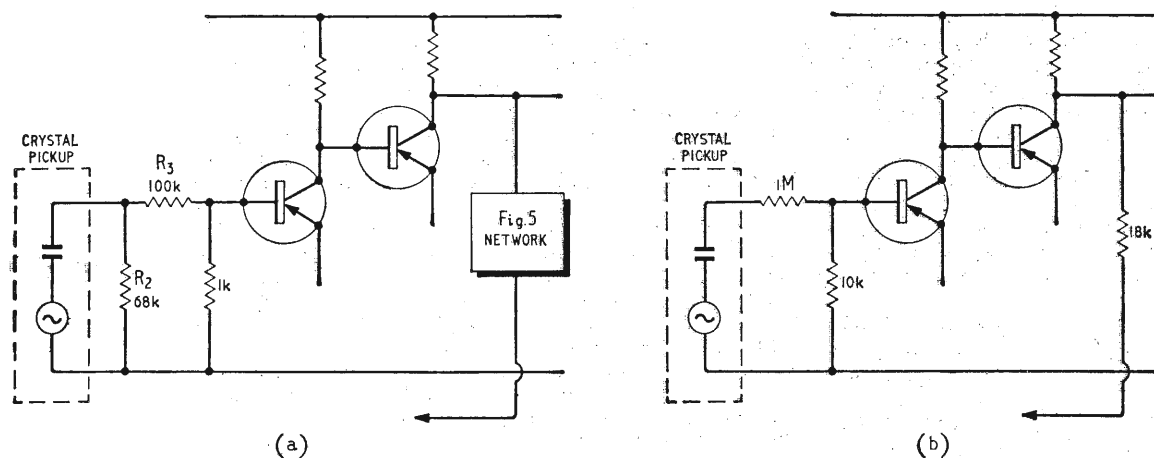

Fig. 6. Two methods of equalization for crystal pickups. (a) Velocity loading. (b) Normal loading.

responses within 1 dB of the standard curves as shown in Fig. 5.

The frequency of the roll-off produced by the inductance of the pickup is given by $f = \frac{R_{in}}{2\pi L}$ where R_{in}

is the input impedance of the pre-amplifier (100 k Ω in this case). Thus for an inductance of 600 mH, a high figure,

$$f = \frac{10^5}{2\pi \times 0.6} = 25 \text{ kc/s}$$

which is sufficiently high to avoid interference with the characteristic.

Crystal Pickup Input

Piezoelectric (crystal) transducers are capacitive sources, and produce an output proportional to the amplitude of the signal. Thus provided negligible current flows no equalization is necessary; an input impedance of 1 M Ω to 2 M Ω will achieve this, and an additional position—"Crystal pickup"—may be added to S1, the input consisting of a 1 M Ω and 10 k Ω potentiometer (to allow for the high output level of crystal pickups and also to load the base of Vt1 to ground via a low impedance to preserve the signal-to-noise ratio), and a with a single 18 k Ω resistor in the feedback network. This will give a sensi-

tivity of 400 mV, which is typical of modern high-quality instruments. However, in the prototype it was decided to utilize the existing equalization networks by "velocity loading" the crystal pickup, i.e. loading the pickup until the output approximated to an electromagnetic characteristic and then equalizing as before. A load of approximately 68 k Ω will achieve this with the majority of pickups, and the resistor R_2 on the crystal pickup input provides this impedance.

It is difficult to maintain the necessary loading requirements for both magnetic and crystal pickups in this mode of operation, and the solution adopted here is to load the magnetic pickup input to ground via a low resistance when a crystal pickup is to be used. This may be achieved either by the use of jack plugs and sockets or (in this instance) by inserting a spare coaxial plug containing the extra resistor. It must be emphasized that this is by no means an accurate "impedance matching" component—it is used solely to allow for the high output of these pickups and to ensure a very low noise figure. A 1 k Ω resistor will result in a sensitivity of 400 mV as before. The two arrangements are shown in Fig. 6. If a higher output device is used additional attenuation may be provided by reducing the additional resistor (and, incidentally, improving still further the signal-to-noise ratio). Thus if the resistor is made 470 ohms, the sensitivity is reduced to 1 volt.

Fig. 7. Tape replay characteristic with equalization for 7½ in/sec.

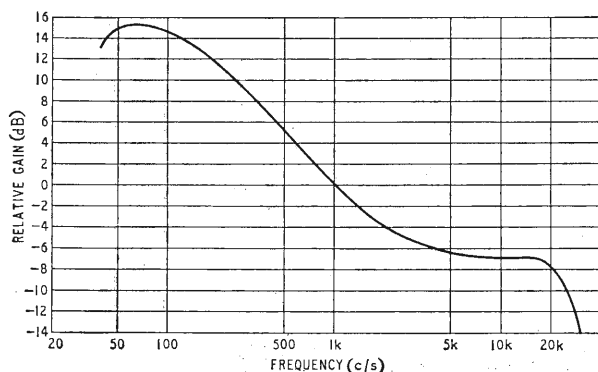

Auxiliary Inputs

In the "Radio" and "Microphone" positions a flat response is achieved by simple resistive feedback via R_{20} and R_{21} , sensitivities being 80 mV and 5 mV respectively. The "Tape" input provides equalization to the C.C.I.R. standard for a tape speed of 7½ inches per second. The characteristic within 1 dB of the standard from 70 c/s to 15 kc/s is shown in Fig. 7 and is independent of the replay head inductance. If preferred, equalization may be carried out at the tape deck, and the selector switch set to the "Radio" position for a flat characteristic. The sensitivity as drawn is 3 mV.

The signal-to-noise ratio is typically -70 dB (wideband measurement), but this may be increased to -85 dB by selecting transistors. Harmonic distortion is of the order of 0.01%, for signals up to 20 dB overload, when it rises sharply.

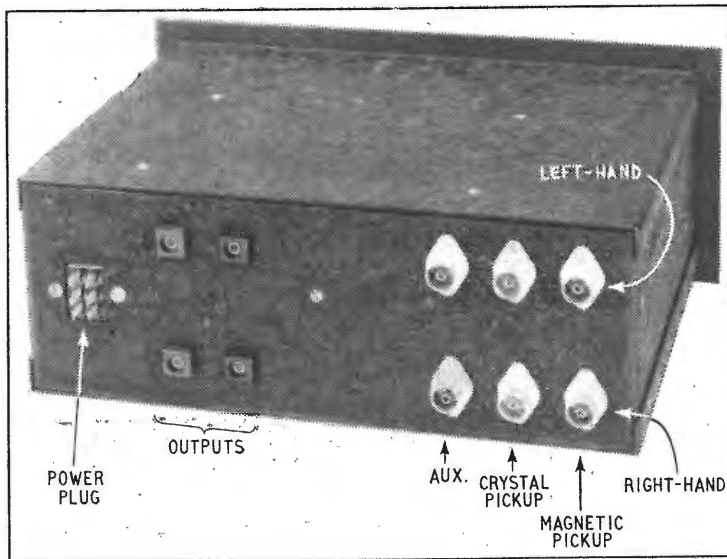

Rear view showing arrangement of input and output sockets.

The pre-amplifier will operate off the main amplifier 40-volt line with a suitable series dropping resistor R_{32} . Otherwise a 12-volt source is adequate. The current consumption is 2.7 mA.

Tone Controls

The tone control and filter circuits are very similar to the original design, being performed by negative feedback around the final stage. The tone control consists of a Baxandall network at the input to $Vt3$. For correct operation, the two capacitors C_{14} and C_{17} should be close-tolerance components. The use of switched tone controls is of doubtful value in a mono equipment except to obtain an accurate "level" position at the centre of the control. However, in stereo systems the more accurate ganging between channels obtainable with switched controls may be an added advantage. Ganged potentiometers are now available, however, accurate to within 1 dB at little extra charge. The tone control characteristics are shown in Fig. 8.

Three fixed low-pass filters were provided giving cut-off frequencies of 20 kc/s ("flat") 10 kc/s and 5 kc/s. As in the original design, the slope of attenuation varies with the setting of the corresponding tone control, since both filter and tone control are achieved by feedback round the same transistor. The maximum boost position of the tone control gives the greatest slope of the corresponding filter. This ensures maximum discrimination against frequencies outside the audio band, when they would otherwise prove most objectionable. The filter characteristic is shown in Fig 9.

Balance

The original form of balance control (Fig. 10) was abandoned since its operation (by varying the collector load of the output transistor) resulted in noise at the output, and gave insufficient variation in channel gains to compensate (for example) for a different loudspeaker on each channel. In addition the tone controls were affected unequally by altering the fraction of the output fed back, since this fraction is determined by the ratio $R_A : R_A + R_B$, and for identical performance from both channels this ratio must be maintained.

The new design uses a conventional log/antilog ganged potentiometer at the output for minimum attenuation at the balance point and infinite variation between channels.

It would be possible to use a dual ganged linear potentiometer, but as will be seen in Fig. 11, this results in an attenuation of 50% at the central (balance) point,

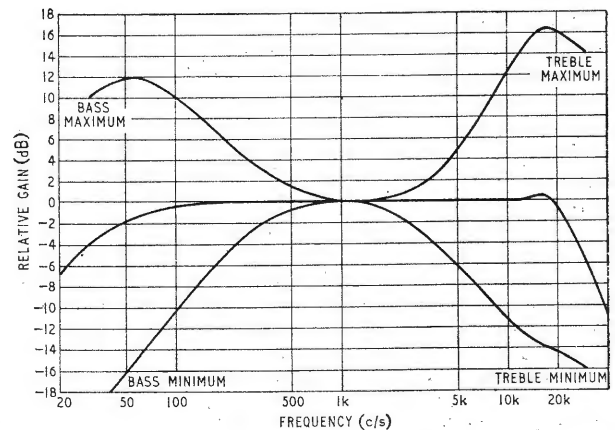

Fig. 8. Pre-amplifier tone control characteristics (low-pass filter at 20kc/s).

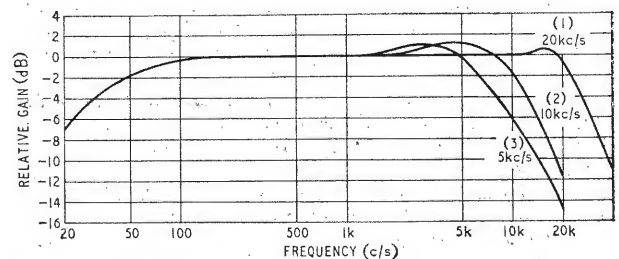

Fig. 9. Low-pass filter response (radio input).

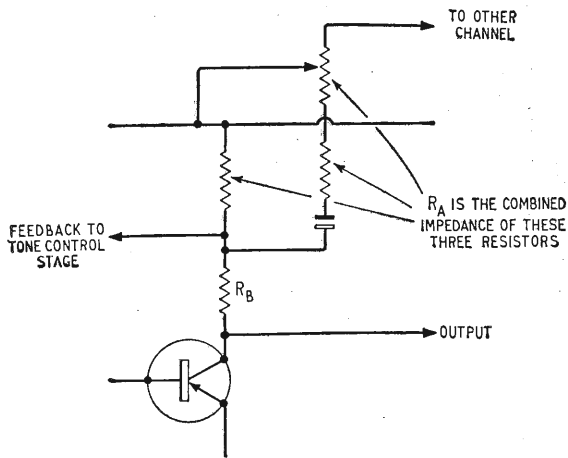

Fig. 10. Original balance control.

while the use of a log/antilog combination results in an attenuation of only 10%.

Since the volume control further loads the wiper of the balance control to earth via 10kΩ, the above attenuation figures become approximately 60% and 15% respectively.

Power Amplifier

Turning now to the power amplifier circuit, Fig. 12, several points arise that may be modified quite readily to give improved performance.

(i) When switching on this amplifier there is a loud "plop" from the loudspeaker owing to the output capacitor C_7 charging to approximately half the supply voltage. While this may be aggravating (acting as it does like the "Surprise" in Haydn's Symphony) it does at least signify (in the absence of hum and noise) that the equipment is "on." However, on a more serious note it may spell ruin to a loudspeaker system costing four times the price of the amplifier. A simple, if bulky, remedy is to use two capacitors in series across the supply, thus providing an artificial a.c. centre tap.

(ii) The bootstrap capacitor C_6 , while linearizing the l.f. response may also induce distortion by pulling V_{t3} into the non-linear (bottoming) region of its characteristic on large negative-going signals. It has therefore proved worthwhile to connect a 1kΩ resistor in series to minimize this effect. The capacitor still improves the l.f. response, though to a slightly less extent.

In both the original articles the need for correct earthing was emphasized since a 1-amp pulse of current in 1 milliohm of wire will produce a p.d. of 1 millivolt, one quarter of the input sensitivity on magnetic pickups. The current pulses in the earth line are asymmetrical, causing severe even-harmonic distortion.

Unfortunately, the stereo equipment will inevitably destroy the utility of all the above by causing an obvious but unavoidable earth loop. Fig. 13 shows two similar amplifiers operating from the same power supply (with individual decoupling). The signal earth points at the inputs will both differ by several hundred millivolts from true earth depending on the signal in each channel. Connection of a commercial stereophonic pickup or microphone with a common earth line now causes each

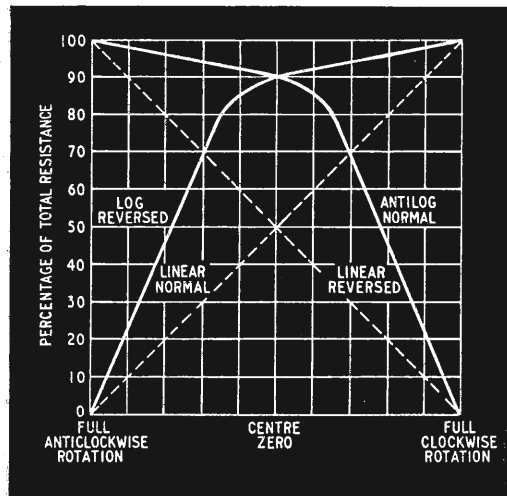

Fig. 11. Dual-gang log-antilog balance control gives less attenuation at centre point.

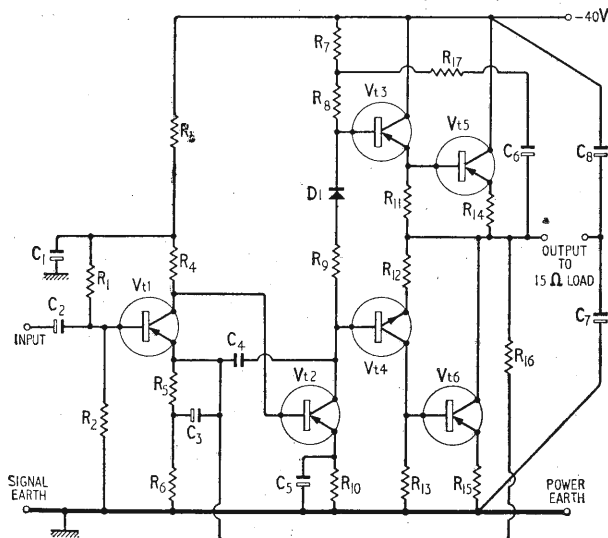

Fig. 12. Circuit of original power amplifier.

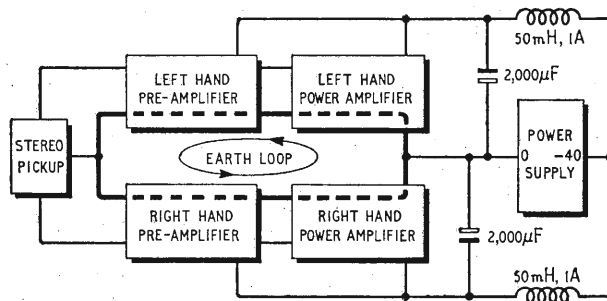

Fig. 13. Earth loop in stereo system.

pre-amplifier and offered valuable comments and criticism during the development. He is also indebted to P. Lepine for carrying out the experimental work in optimizing and plotting the response curves.

[To be concluded. Full dimensioned drawings of metal-work, printed circuit and wiring diagrams will appear in the next issue together with hints on construction.]

REFERENCES

- ¹ R. Tobey and J. Dinsdale: "Transistor Audio Power Amplifier." *Wireless World*, November 1961.
- ² R. Tobey and J. Dinsdale: "Transistor High Fidelity Pre-Amplifier." *Wireless World*, December 1961.

APPENDIX

$$i_L = \frac{(e_H - e_V)}{|Z_H + Z_V + R|} \quad \text{and similarly } i_R$$

$$E_L = (e_H - e_V) - i_L |Z_V + Z_H| + i_R |Z_H| \quad \text{and similarly } E_R$$

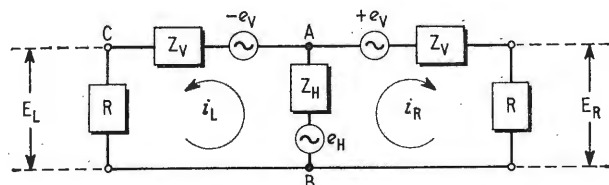

R = INPUT IMPEDANCE OF AMPLIFIER

E = APPLIED SIGNAL FROM PICKUP

The channel separation is given by

$$\frac{\frac{(e_H - e_V)}{|Z_H + Z_V + R|} \cdot Z_H}{(e_H - e_V) - \left(\frac{(e_H - e_V)}{|Z_H + Z_V + R|} \right) (|Z_V + Z_H|)}}{\frac{|Z_H|}{|Z_H + Z_V + R|}} = \frac{1}{1 - \frac{|Z_H + Z_V|}{|Z_H + Z_V + R|}} = \frac{|Z_H|}{|Z_H + Z_V + R| - |Z_V + Z_H|}$$

Where R is large, the effects of Z_V and Z_H are negligible. However where R is of the same order as $|Z_H + Z_V|$, about 2 to 12K, the channel separation will be seriously degraded; and since Z_H and Z_V are frequency-dependent, this effect will worsen with increasing frequency.

In addition, the lateral/vertical sensitivity will depart from the ideal ratio of 1 (an effect pointed out by Mr. D. G. Jaquess). The effective lateral sensitivity measured between points A and B will be $(e_H - 2i_L |Z_H|)$ because both currents flow in Z_H , while the effective vertical sensitivity measured between points A and C will be

$$(e_V - i_L |Z_V|). \quad \text{Thus the ratio } \left(\frac{e_H - 2i_L |Z_H|}{e_V - i_L |Z_V|} \right)$$

will be dependent on both frequency and current and hence on loading.

Measurements taken on the Decca "ffss" Mk. II pickup tend to support this theory, but there are other factors involved, such as the mutual coupling mentioned earlier.

CATHEDRAL SOUND

MANY of the beautiful architectural features of the new Coventry Cathedral—the high absorbent roof canopy, the tapestry at one end of the nave and the highly reflecting engraved glass curtain window at the other—have presented unique problems for the acoustic consultants who have been called in to provide electroacoustic reinforcement, so that all members of the large congregations can hear well. Sound projected longitudinally down the aisle, even when suitably delayed to compensate for time lags in propagation, has failed to remove confusion of sound because it is overlaid by the strong return from the end window.

A new system, designed by F. H. Brittain and his colleagues at the Hirst Research Centre of the General Electric Company Ltd., relies on a single group of loudspeakers high in the roof and has satisfactorily solved the problem. The sound is directed principally toward the back of the nave where the requisite delay (about 60 millisecc) is obtained simply by the increased height of the source. If the sound level is correctly adjusted one is not conscious that the sound is coming downwards, but the steep angle ensures that reflections from the floor of the aisle and from the back window are returned upwards instead of longitudinally over the congregation, and are soon lost in the absorbent roof canopy. The directional properties of the loudspeaker array are such that in the front rows there is negligible reinforcement (delayed) to interfere with direct hearing of the preacher's voice.

There are 27 microphone positions, controlled from a console with mixing facilities at the back of the nave. Audio power is supplied by two 50 watt amplifiers, but for normal speech only about 7 watts is, in fact, required.

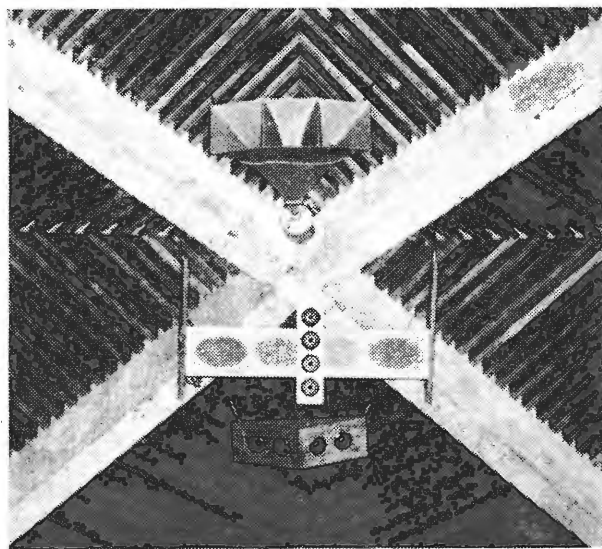

The loudspeaker group consists of two short column arrays, a medium-frequency 3-cell horn and two pairs of h.f. units to improve articulation in the front corners of the nave.

A major problem for the electronics industry is the real shortage of people with the right practical qualifications for research, laboratory or development work, for production control and kindred activities. In particular, people capable of operating the wide range of standard instruments to be found nowadays in most electronic laboratories are hard to come by.

"Wireless World" recognizes that a real need exists in this field for an integrated, up-to-date, informative set of articles on the practical aspects of laboratory instruments. It has therefore commissioned Mr. T. D. Towers to write a series entitled "Electronic Laboratory Instrument Practice," starting in this issue. Mr. Towers is already well known to our readers for his series of articles on "The Elements of Transistor Pulse Circuits" which ap-

peared throughout 1964, and for his "Transistor Television Receivers" (Iliffe Books Ltd.).

The material in the new series is carefully selected to form a comprehensive well-organized course. Basically it will give clear detailed information about the commonplace instruments of the electronic laboratory. Much has been written on this subject in the past, but few surveys covering the range of basic test equipment furnish also practical instruction in their methods of use.

When you work in an electronics laboratory, you come in time to use all the measurement instruments almost subconsciously. But when you first join such a laboratory, you find the array of meters, signal generators, oscilloscopes, bridges, etc. quite frightening. Even though you have been through a course in laboratory instrument practice at a University,

ELECTRONIC LABORATORY INSTRUMENT

By T. D. TOWERS,* M.B.E., A.M.I.E.E., A.M.I.E.R.E.

ELECTRONIC instruments have been in general use for about half a century, but it was only the technical impact of the Second World War that brought such precision measuring equipment on to every lab. bench. Also the scope of measurement has widened greatly and nowadays measurements of frequencies up to hundreds of megacycles, currents down to fractions of a millimicroamp and voltages down to fractions of a millivolt are commonplace.

A series of articles like this can cover only the broader aspects of electronic instrumentation. A whole library of text-books would be required to cover details. My aim is mainly to show the newcomer what sort of instrument he would normally use to measure what, and to offer practical advice on the use and care of these instruments. The discussion will not be limited to the enticing array of new instruments offered by the manufacturers from time to time. The series must be retrospective too, because most people reading the articles will be "stuck with what they have got," and, most laboratories usually end up with "something old, something new, something borrowed and" . . . an intense wish that they had something else!

Transistors have been much used in recent instrument models and have brought the usual semiconductor advantages of smaller size, greater robustness and longer life. But transistorization has brought a new problem. The spate of redesigned transistorized models is so persistent that you will find difficulty trying to keep up with them.

Instrument presentation, too, has been changing rapidly. In the old days, you could walk into a laboratory and, if you had a little experience, you could identify every piece of equipment on sight. Nowadays it has become in-

creasingly difficult to work out what an instrument is by merely looking at its front panel. One of my objects is to familiarize you with the general appearance of the instruments in common use. Take Fig. 1, which is an illustration of a corner of my private laboratory. If you are an experienced electronics man, you will be able to identify the instruments in the picture fairly correctly. If you are a newcomer, you may be puzzled by some of the "prehistoric" models I continue to use because I "like the feel of them." The large instrument on the extreme right, for example, is an ancient r.f. generator. I keep using this because it has an excellent attenuator, which (despite its age) is better than many fitted in present-day instruments.

Instrument Types

You can divide electronic lab. instruments into three main classes:—

1. *General-purpose*: instruments in almost daily use in every electronics laboratory.
2. *Special-purpose*: instruments in daily use in laboratories specializing in a particular field but not in the general run of laboratories.
3. *Esoteric*: instruments only occasionally required for extra special measurements.

In the general-purpose class, can be listed seven basic instruments: (1) multimeter, (2) d.c. power supply, (3) a.f. generator, (4) r.f. generator, (5) oscilloscope, (6) valve voltmeter, (7) transistor (or valve) tester.

Fig. 2 shows a typical set of these basic instruments in use in the Applications Laboratory at Newmarket Transistors Ltd. at the time of writing. Most of them are standard commercial equipments.

Besides these basic instruments, most laboratories use

* Newmarket Transistors Ltd.

technical college, or school, you will find that practising engineers use techniques and "short-cuts" which never seem to get reflected in text-books.

If you are going in for electronic work in a professional (or even serious amateur) capacity, you should find the series rewarding, as it is aimed primarily at the "new recruit". It should be particularly useful to those who have obtained all the necessary paper qualifications like O.N.C., H.N.C., or B.Sc., and find themselves projected into the disquieting turmoil of a commercial electronic laboratory to "find their own feet".

But the series is not for the beginner only. It will also make useful reference material for practising engineers who have reached positions where they are "away from the bench" and thus unable by personal experience to keep up with the changing field of laboratory instrumentation.

The author will try to instil into the series the true atmosphere of the working laboratory. The aim is to keep the text at a level which will be most appreciated by the student and experimenter who is ever seeking to extend his knowledge. While essentially a practical guide written with emphasis on applications and testing methods, the articles will also consider basic design and circuit features where necessary to appreciate the full scope and diversity of instruments—and their limitations.

As the Chief Applications and Measurements Engineer of Newmarket Transistors Ltd., the author runs a large modern electronics laboratory with a wide sphere of activity. Through this and his own private laboratory, he has a specialized practical knowledge of modern electronic laboratory practice which assures the reader of an authoritative practical treatment of the subject.

PRACTICE

1.—INSTRUMENT REQUIREMENTS

special-purpose instruments related to their particular interests. Typical of these are admittance bridges, v.h.f. millivoltmeters, distortion meters, wide-band oscilloscopes, and pulse generators. A small selection of typical special-purpose units in use at Newmarket is shown in Fig. 3.

Apart from general and special-purpose instruments,

anyone who works in a lab. will occasionally come across *esoteric* instruments used to carry out very specialized measurements. In this class are things like spectrophotometers, ion gauges, scintillation counters, and intermodulation test sets. Fig. 4 gives a typical example—a transistorized crystal-controlled clock with digital readout facilities. The general use of this sort of thing is so infrequent that many engineers can go through life without ever handling one.

Many things control the selection of instruments in these three classes. Not the least is cost, and sensibly you should look at this as an accountant would. Work out the cost of writing off the capital value of a piece of equipment, together with its maintenance costs, and decide whether it is more economical in end cost (i.e., counting engineer time, etc.), to buy commercially or

Fig. 1. Corner of Author's private laboratory with typical instruments: — 1, D.C. power supply; 2, Valve, voltmeter; 3, Oscilloscope; 4, Multimeter; 5, Audio generator; 6, Transistor tester; 7, R.F. signal generator.

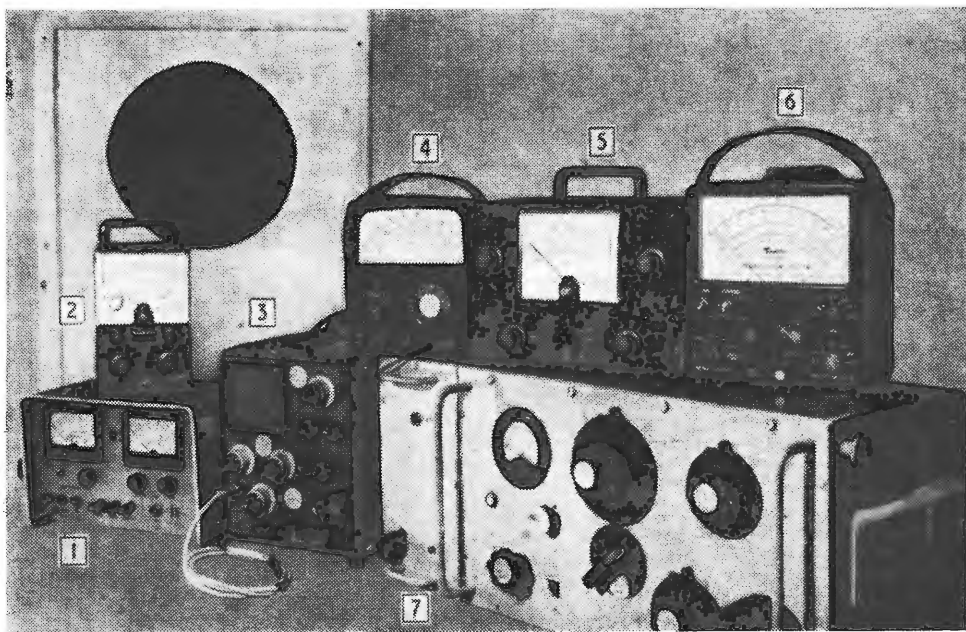

make do with a lab. "lash up." This simple rule will prevent the accumulation of white elephants, a failing of many laboratories. Of course there is always the difficulty that commercial equipment may not be available. In the forefront of the transistor business particularly, where new parameters keep appearing, I find you have to keep designing and building your own. But for the average engineer in electronics this situation does not arise.

Commercial literature often emphasizes the versatility of equipment, but this can be a snare. Always remember that an instrument, however versatile, can only be in one place at one time. Accessories too, should be approached with caution. Provided a good basic instrument is available, it is surprising how little use need be made of the accessories offered with it. Always spend money on the basic instrument rather than on the accessories.

One set of accessories on which it is worthwhile spending money, however, is in equipment mounting. With lab. floor space at such a premium, there is much to be said for mounting instruments (particularly those not too frequently used) on standard 19in Post Office racks. Also any large oscilloscope ought to be mounted on a trolley, as it is so liable to be damaged by being passed about by hand from one engineer position to another.

Instrument Procurement

Where you are faced with a problem of getting a new instrument you can buy new, buy second-hand, build yourself, or (a recent development) hire. This last facility is particularly good for "one off" projects.

The advertisement columns of the electronics journals such as the *Wireless World* give full details of new equipment, and instrument suppliers are always pleased to send you leaflets. Second-hand equipment is more difficult and for the beginner probably the best advice is "don't." New equipment can also be obtained pre-assembled from the do-it-yourself kit manufacturers. Many laboratories buy in kit form and assemble themselves, using the exer-

cise for training juniors at the same time. Because of all this, many labs. display a curious miscellany of makers. There are, however, advantages in getting your equipment as far as possible from one maker. Unless you are a real instrumentation expert, always go to a standard instrument manufacturer, and pay the price he asks. You will get value for your money. You may be surprised at how apparently expensive the equipments of reputable manufacturers can be, but you should recognize that in a properly equipped lab. the electronic instrument capital investment per bench engineer can run to something approaching his annual salary.

Instrument Care

Always look to the safety of your instruments. Treat h.t. voltages with respect. If you do have to open up an instrument (such as an oscilloscope) with dangerously high voltages, be extra careful. Remember the old engineers' rule (always repeated by *living* grey-haired experts) "When you are messing about with high or unknown voltages, keep one hand in your trouser pocket, look down to see that the floor you are standing on isn't a good conductor, and move wires, etc., with the back of your fingers, so that if you *do* get a shock and involuntarily contract your hand the contact is broken."

Instruments are expensive. Despite manufacturers' claims of ruggedness (particularly in this transistor era) always treat an electronic instrument as if it were a cup of tea brimming to overflowing. Always see that it is regularly serviced and calibrated. Try to keep a log book for each instrument, and, if this is impossible, at least tie on to the handle a label on which its history is recorded. If for your own purposes you bring out 1,000 V to a front terminal, which normally has only 10 V on it according to the hieroglyphics on the panel, see that a temporary label is tied on.

Before you use an instrument you are not familiar with, check the earthing, fusing, and the mains voltage tappings. Remember that American equipment is de-

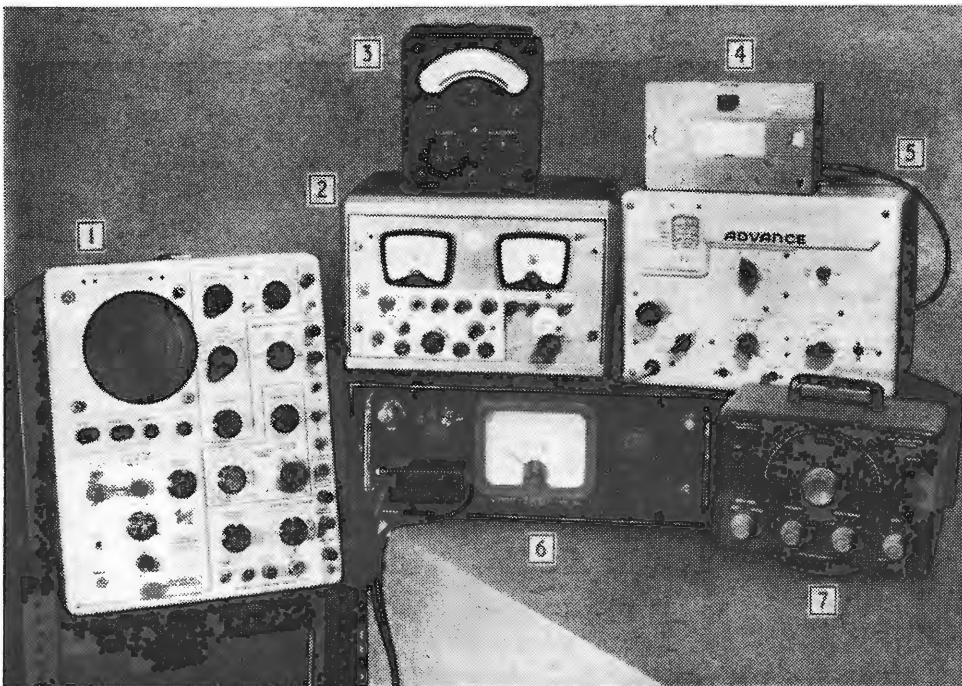
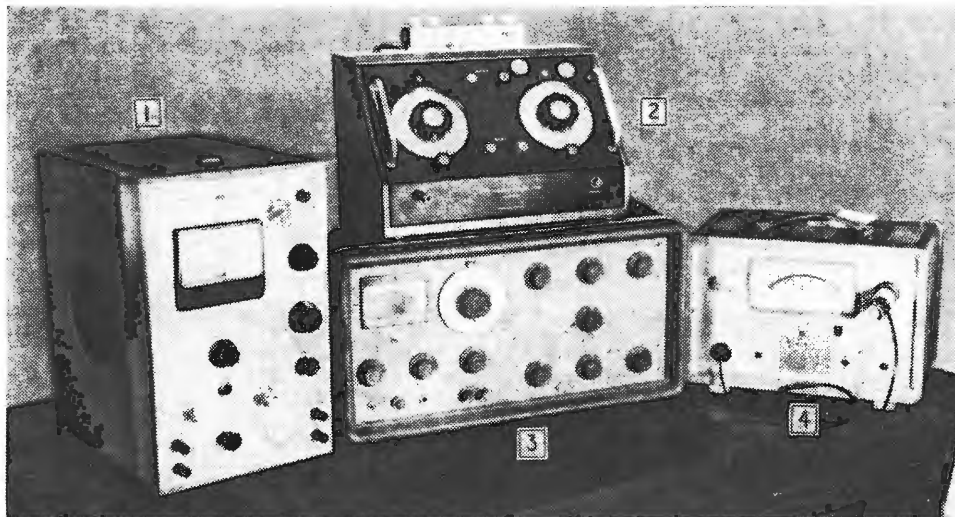

Fig. 2. Seven essential laboratory general purpose instruments (examples in use at Newmarket Transistors):—1, Oscilloscope; 2, Power supply; 3, Multi-meter; 4, Transistor tester; 5, R.F. Signal generator; 6, Valve voltmeter; 7, Audio generator.

Fig. 3, Special-purpose instrument selection:—1, Pulse generator; 2, R.F. admittance bridge; 3, Total distortion meter; 4, V.H.F. millivoltmeter.



signed to work on 110-120 V, 60 c/s, a.c. and British (normally 230-250 V 50 c/s. When you are using a scope, never leave the beam focused on a single spot, as this may burn the tube and leave a dark mark. When you are using very sensitive meters, always short the input terminals when you have finished. The simplest way is to take a piece of rosin-cored solder and wind it round the two terminals; you can snap the excess solder off without a pair of cutting pliers. Finally, do not, as so many engineers do, use the multimeter cut-out as a circuit protection. The voltmeter is provided with a cut-out to protect itself and not the equipment you are working on. Too frequent overloading of the cut-out can seriously mar the accuracy of the multimeter.

Instrument Accuracy

When you first start to use electronic instruments, you tend not to question their accuracy. I have found that the average electronic engineer has a surprising faith in the accuracy of his instruments. Time and again I find myself saying "How accurate are these figures?"

Fig. 4. Esoteric instrument example:—Electronic unit of microbalance with combined analogue-digital readout (courtesy Cambridge Consultants).



I then launch into a more precise question. "What is the probable error and what is the maximum possible error?" I then find that I am wandering off into a disquisition on the mathematical theory of errors, so I reduce the matter to a simple challenge . . . "Will you give me a shilling (or ten shillings depending on the importance of the point) for every figure that I can prove to you is more than, say 10% wrong?" Over the years I have found that engineers divide into two distinct categories: those whose results I would usually accept without checking because, nine times out of ten, I find that I would be wasting my time doing so; and those results I am loath to accept without some form of cross-check.

It seems to be a matter of basic intelligence. The good engineer is a scientist at heart and recognizes that an electronic test instrument is only a tool. Take a clock. Just because the hands point to 4 o'clock, you don't assume that it shows the correct time. You normally assess the error, probably sub-consciously, by, say, looking out the window at the state of the light. You should do the same with lab. instruments. Always mentally assess the probable error in what you are recording. Until you get the feel of things and acquire the ability to cross-check readily, you should be over-cautious. Your motto could well be, parodying Descartes, "Dubito, ergo sum," i.e. take nothing for granted.

Now, you read an instrument by looking at a pointer on a scale, a setting of a dial, a figure in a digital readout, and so on. There are really two problems here. First, you must consider how *precisely* you can make the reading that the instrument shows. Second, you must decide how *accurately* what the instrument shows represents the quantity being measured (however precisely you make your actual reading of the display).

With a digital readout, under most circumstances, the precision of the reading is exact because the value appearing is a whole number. With analogue type instruments such as meters, the precision depends on such things as the angle at which you look at the needle or the scale against which you are reading it. A good guide is never to try to read more closely than to the smallest printed scale division. This works on the assumption that the instrument manufacturer prints his scale sensibly . . . as he usually does. This problem of reading precision is illustrated in the voltmeter scale of

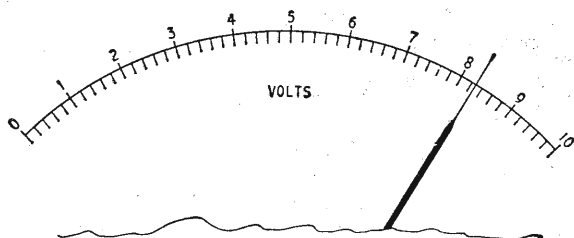

Fig. 5. Meter scale illustrating method of rounding off readings.

Fig. 5. Here a wise man would read 8.2V only and not attempt to interpolate within the smallest scale division. In this matter of "rounding off," be consistent. I always round off to the nearest scale line, and, when the needle falls halfway between two lines, round off to the nearest *even* scale number (B.S. 1957:1953). Where you record rounded off numbers like this, carry your decimal place only to the actual number rounded off. In the case above, the reading should be recorded at 8.2 V and not 8.20 V.

While you must always consider the question of the precision of your readings, their accuracy is a much more difficult and important problem. There are two aspects of this. One is how closely the instrument displays the real value of what it measures. The other is how much the instrument upsets the circuit it measures, i.e. how far it fails to measure accurately because it changes the quantity being measured.

We recognize that an instrument must display a reading different from the actual quantity applied to its terminals. The important question is how different. This depends on two things. First, how accurately the instrument reads by its intrinsic design, i.e. even if the instrument is new and freshly calibrated it will have an intrinsic possible error. Take the case of a good general purpose multimeter. When it is new, the reading of a quantity in any scale can be out by up to ± 2 or 3 % of full scale deflection. Very soon, with normal laboratory manipulation, it can become materially worse than this. Experienced engineers know the expected theoretical accuracy of an instrument and, as a precaution, mentally double this possible error if they cannot check before they have to use it.

In meter-type instruments, you should remember that the accuracy is specified as a percentage of the full-scale deflection. Specifications are not always clear, but usually for an instrument specified as of 2% accuracy the full-scale deflection reading can be in error $\pm 2\%$. Remember also, that this error remains fixed in absolute value across the scale, so that if you attempt to measure a quantity at a tenth of the full scale deflection, the possible error of the reading can still be $\pm 2\%$ of the full scale value, i.e., $\pm 20\%$ at the low value. This is, of course, why most good multi-scale instruments have overlapping scales, so that you can read any quantity without having to go below about one-third of full scale deflection. This is also why you will often hear the advice: "Try to keep the meter needle up."

Never forget that when you put a measuring instrument on a circuit, you change the quantity you are measuring, so that even with a perfectly precise, perfectly accurate instrument the value you read will not be the true value in the absence of the instrument. The important thing is to be able to judge how much you have modified the quantity measured. This point will be

covered in later articles in some detail, since the increasing use of silicon transistors operated at very low currents has meant that the effective loading of instruments on circuits is becoming a major problem. A simple rule that I follow is to assume that if the current being measured is more than a hundred times the full-scale deflection (f.s.d.) current, the instrument has a negligible effect on the parameter being measured.

To ensure the maximum possible accuracy when using instruments, always use standard good measurement practice by seeing that the instruments are properly earthed, properly screened (where necessary), and set to the proper range. Also, always see that adequate time is allowed for an instrument using valves to heat up and "settle down."

Always try, if only mentally, to cross-check your reading in some way. This may be merely the simple process of stopping and thinking, "Does this value make sense? Is it in accordance with what I would expect from my experience in the field?" Always try to look past the figures to the actual value itself. Apart from this, always try to assess the accuracy of the instrument you are using. Look at the label to see when it was last calibrated and, where the question of accuracy is important, check the instrument against a standard, or have it calibrated.

Laboratory Calibration Standards

By now you should begin to see why every lab. should have something to check the instruments against, i.e., some standards. Instruments are obviously of little useful value unless they are checked regularly. In later articles I will discuss the question of standards more fully, but at this juncture it is worth pointing out that for calibration you should use a standard with an accuracy greater than you want from your calibrated instrument. Standards are of two general types, "primary" and "secondary." Primary standards are of a very high accuracy. Normally this means an error of less than $\pm 0.05\%$ as compared with the absolute reference standards maintained by one of the central institutions. These sort of standards are usually maintained only by instrument manufacturers. Most standards used in ordinary laboratories are secondary ones, which compare with the absolute standard to about $\pm(0.1-0.5\%)$. In calibrating an instrument of, say, 1% accuracy, the standard should, if possible, be better than 0.1%, i.e., ten times more accurate.

The standards ideally required in a laboratory are: (a) potentiometer test set, (b) self-contained power source, (c) standard resistance, (d) standard inductance, (e) standard capacitance, (f) standard frequency, (g) standard timebase. Although ideally a lab. should have all these standards, precise voltage and current sources are the most important.

Reference Material

So far it has been largely a matter of "setting the picture" on lab. instrumentation. Later articles will fill out some details, but the field is so large that the engineer will want to look to other sources of information. In this respect, anyone who works with electronic instruments should keep at hand standard reference material for guidance. Even in the author's modest laboratory, the array of reference books pictured in Fig. 6 is in constant use.

A wide range of text-books is available, and some

guidance is not out of place on this. The more commonly used text-books relating to laboratory electronic instrumentation to be found around lab. benches are listed below in alphabetical author order. Each of these contains valuable reference material, much of it most practical, and are worth looking at even if you don't want to buy them.

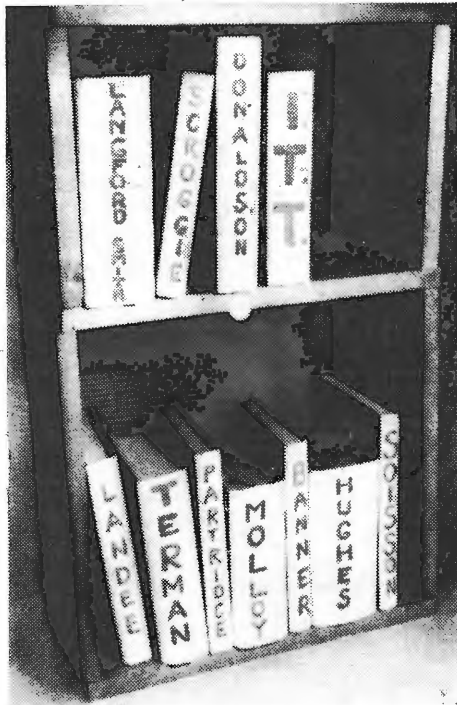

Fig. 6. Standard reference books in common use by the author in the field of instrumentation.

Of all these titles I have found over the years four volumes which I think no laboratory should be without—"Langford-Smith", "Scroggie", "Donaldson" and "I.T.T."

In the matter of reference material the service manuals

Author	Book	Publisher
Banner, E. H. W.	Electronic Measuring Instruments	Chapman & Hall
Donaldson, P. E. K.	Electronic Apparatus for Biological Research	Butterworth
Hague, B. K.	A.C. Bridge Methods	Pitman
Harris, F. K.	Electrical Measurements	Wiley
Hartshorn, L.	Radio Frequency Measurements by Bridge and Resonance	Chapman & Hall
Hughes, L. E. C.	Electronic Engineers Reference Book	Heywood
I.T.T.	Reference Data for Radio Engineers	International Telephone & Telegraph
Landee, R. W. et al.	Electronic Designer's Handbook	McGraw Hill
Langford-Smith, F.	Radio Designer's Handbook	Iliffe
Lion, E. N.	Instrumentation in Scientific Research	McGraw Hill
Partridge, G. R.	Electronic Instruments and Instrumentation	Pitman
Prensky, S.	Electronic Instrumentation	Prentice Hall
Risse, J. A.	Electronic Test Instrument Handbook	Howard Sams
Scroggie, M. G.	Radio and Electronic Laboratory Handbook	Iliffe
Soisson, H. E.	Electronic Measuring Instruments	McGraw Hill
Terman F. E. & J. M. Pettit	Electronic Measurements	McGraw Hill
Turner, R. P.	Basic Electronic Test Instruments	Holt, Rinehart & Winston
Turner, R. P.	Basic Electronic Test Procedures	Holt Rinehart & Winston

or instrument handbooks for all the lab. instruments in use should be carefully preserved. A record of any historical features, such as design modifications carried out that can affect the accuracy of the instruments, should be pasted into these.

No laboratory can do without transistor and valve manuals. I have always found the *Wireless World* Radio Valve Data to cover the British market for these devices well. For American and European transistors, however, the most useful reference is "DATA" published by Derivation and Tabulation Associates, 43 South Day Street, Orange, New Jersey.

Conclusion

In this preliminary survey, I have tried to pick out some of the general points that are important in practice; but one should not be "blinded by science." You should, of course, always get hold of the best instruments you can afford and need. But do not think that an impressive array of exotic test equipment by itself will ensure good work. A curious thing is that constructive work seems to come more readily out of laboratories where the electronic test equipment looks a bit seedy, and is not always the most expensive or newest available. Where a lab. is neat and tidy and has a glittering orderly array of test instruments, my experience has been that the place tends to be sterile, and the quantity and quality of the work output from it is generally poor. This is an old story. You can look at a man's bookshelves and judge by the appearance of the bindings whether the owner really uses them or not. A few well thumbed tomes speak volumes.

CLUB NEWS

BRADFORD.—An informal meeting between the members of the Bradford, Spen Valley and Leeds radio societies will be held at 7.30 on January 5th at Cambridge House, 66, Little Horton Lane, Bradford 5.

EAST HAM.—Short-wave listeners and licensed amateurs living on the east side of London are invited to the fortnightly meetings of the East Ham Group of the Radio Society of Great Britain. These are held on alternate Tuesdays at 7.30 at the home of A. A. Leith (G2COG), 12 Leigh Road, London, E.6. Further information from the secretary, D. R. Durham, G3SIR, 43 Victoria Avenue, E.6.

HALIFAX.—At the January 5th meeting of the Northern Heights Amateur Radio Society A. W. Walmsley (G3ADQ) will discuss s.s.b. trends. Fortnightly meetings are held at 7.30 at the Sportsman Inn, Ogdon.

HECKMONDWIKE.—At the meeting of the Spen Valley Amateur Radio Society on January 21st, L. M. Dougherty will talk on aerials for radio astronomy. Fortnightly meetings are held at 7.30 at the Grammar School, High Street.

LEICESTER.—"Parametric amplifiers in the v.h.f./u.h.f. bands" is the title of the lecture to be given by C. L. Wright (G3CCA) at the January meeting of the Leicester Radio Society which meets in the Engineering Dept. of the University.

MELTON MOWBRAY.—"Flat line equipment for 23cm" is the title of the talk to be given by J. L. Warrington (G2FNW) at the meeting of the Melton Mowbray Amateur Radio Society on January 28th. Monthly meetings are held at 7.30 at St. John Ambulance Hall, Asfordby Hill.

WELLINGBOROUGH.—January meetings of the Wellingborough Radio Club, which meets at 7.45 every Thursday at the Silver Street Club Room, include a talk on home-made gadgets by P. Elderkin (14th) and one on transistors by G. Abrams (28th).

RECENT TECHNICAL DEVELOPMENTS

Automatic Degaussing for Colour Television

Demagnetization of the shadow mask and associated ferrous material in a colour television receiver (degaussing) is necessary when a receiver is installed or reorientated in order that the electron beams remain in alignment. Degaussing is achieved by tracing a helix in front of the receiver and away from the tube screen with a coil energized with 50 c/s a.c.

R.C.A. have now incorporated an automatic degaussing feature in their receivers (N.T.S.C.) which removes colour impurity due to magnetization. A purity shield surrounding the tube is used as the pole pieces for four degaussing coils using the usual 50 c/s a.c. By use of voltage dependent resistors and negative temperature coefficient resistors the circuit is arranged such that each time the receiver is switched on demagnetization occurs, the effect decaying during the warming-up period to negligible proportions when the receiver is ready for viewing. Purity magnets which are used for alignment of the three electron beams are to the rear of the receiver and consequently unaffected.

Thin Films

The work of the Electronics Department of the Electrical Research Association at Leatherhead, Surrey, is at present largely concerned with thin film techniques, and some interesting results are being obtained. Electron microscopic examination of gold films deposited on dielectric substrates shows a surprising lack of continuity. Indeed, it is difficult to find continuous paths through the assembly of discreet aggregates into which the metal film is divided, rather resembling a crackle enamel finish in appearance. The cracks are due to the forces of cohesion in the metal being greater than the forces of adhesion within the substrate. Nevertheless, the film as a whole shows better conductivity than the geometry of the fissures would suggest and investigations of the film/substrate system as a whole point to two possible mechanisms for the anomalous conductivity—electron scattering at the film boundaries in a process analogous to tunnelling and initial conductivity in the substrate, particularly when this is a polar dielectric like glass.

Other work in this field being undertaken by E.R.A. is directed to discover

the effect of the presence of impurity gases on the dielectric properties of the silicon monoxide films widely used in microcircuits, and also the feasibility of depositing circuit elements and interconnections by writing with a beam of positive metal ions. Deposition of metal from ion beams has hitherto been bedevilled by dilution with neutral atoms and by other factors which prevent efficient collimation and the production of a small spot size. Present work is directed at the improvement of vacuum arc sources of copper ions.

Electronic Stop and Coupler Actions for Pipe Organs

It has in the past been customary to effect the coupling of the pipes to form "stops" in conventional pipe organs by means of mechanical "tracker" mechanisms or a multiplicity of relay contacts in organs with electric actions.

The advent of semiconductor logic switching has opened up the possibility of more silent and reliable action and the appropriate circuitry is discussed by A. K. Cabrera in *A.W.A. Technical Journal*, Vol. 13, No. 1 (Sept. 1964).

Each manual in a pipe organ has a number of stops associated with it. These stops operate ranks distinguished by their tone colour (e.g., diapason, flute) and for each note there are a number of pipes, each rank having one of these pipes as a member. It is evident that

before a note or pipe can sound a key must be depressed AND a stop pulled. In addition to these "speaking" stops, there are a number of stops coupling manuals which allow a note to be played on say the Swell manual and the corresponding note to play on say the Great manual. In other words, a given note on the Great manual will sound if that note is played OR if the corresponding note is played on the Swell manual AND the Great to Swell coupler stop is drawn, OR, etc.

To complicate matters, the extension principle is used (in order to reduce the total number of pipes). Given a basic Swell rank notes may be borrowed by the Great Manual or the Pedal organ and other ranks can be simulated.

A typical logic diagram for one note on the Swell manual of a small organ is shown in Fig. 1.

In electromagnetic pipe organs relays are used to perform the logic functions and considerable saving in cost can be achieved by using diodes and in addition we have their greater reliability and faster action. Due to the power requirements of the electromagnets operating the note valves, for example 12 V at 150 mA, use of the diode logic will cause high dissipation in some resistors and consequently transistor logic is an obvious advantage. A simple two manual organ with about 250 pipes may require about 600 transistors and resistors and 250 diodes in a typical arrangement.

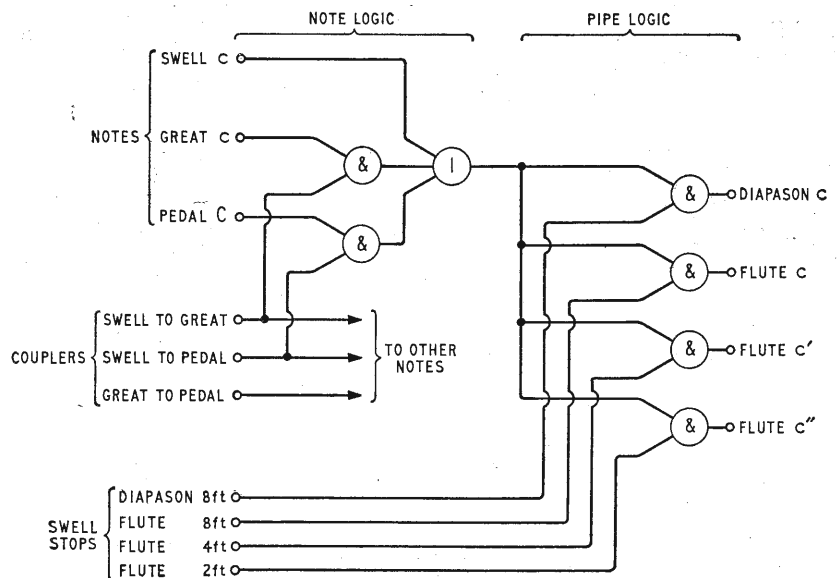

OSCAR III

By W. H. ALLEN,* M.B.E., G2UJ

THE third of the Oscar series of satellites is now undergoing final ground tests in the United States in preparation for launching later this winter, the actual date depending upon the availability of space in a suitable American research rocket vehicle.

Unlike Oscars I and II, transmission from which consisted of the morse letters "HI" sent continuously on a frequency of 145 Mc/s with a radiated power of 100 mW, Oscar III will be a translator satellite capable of receiving signals over a 50 kc/s portion of the "two metre" amateur band centred on 144.1 Mc/s, changing their frequency without demodulation, and reradiating them on another 50 kc/s segment of the band centred on 145.9 Mc/s. The actual frequency limits will thus be:

Receiving 144.075 to 144.125 Mc/s.

Transmitting 145.925 to 145.875 Mc/s.

It will be appreciated that in the process of translation, frequency inversion will take place, a station operating on, say, 144.075 Mc/s being retransmitted on 145.925 Mc/s. Thus, with a single-sideband transmission in which the upper sideband is transmitted by the ground station, it will appear as the lower sideband when received from the satellite.

All forms of modulation including c.w., narrow band f.m., a.m. or p.m. telephony and teleprinter may be employed.

A modification of the frequency limits, both for acquisition by Oscar III and for reception of the translated signal by a ground station, may be caused by Doppler shift due to the speed of the satellite relative to the transmitting and receiving stations concerned. A maximum frequency shift of 8 kc/s is anticipated when the track of the satellite passes immediately above the receiving station and must be allowed for when tuning over the translated band of signals.

The average output power of the main transmitter in the satellite will be one watt, and automatic gain control in the receiver section will ensure that this is not exceeded by even the loudest incoming signal. It will be imperative, therefore, that amateurs attempting to make contacts via the satellite restrict their power to such a level that this a.g.c. is not brought into operation, otherwise a reduction in the strength of all other signals being handled by Oscar III at that time would occur.

Two further transmitters will be carried, one a beacon radiating a continuous unmodulated 100 mW carrier on 145.950 Mc/s for tracking purposes and the measurement of Doppler shift, and the other, on 145.850 Mc/s, for telemetry. This will take the form of the morse letters "HI," the speed of sending varying according to the information being transmitted, together with variable width pulses between the Morse characters to convey the state of the power supply.

Receiver and Aerial Recommendations

For reception of signals from Oscar III a combination of a crystal-controlled converter feeding into a communication receiver which provides the variable first i.f., as generally favoured by operators on the 144 to 146 Mc/s amateur band, is to be recommended, and as all transmissions from the satellite including the beacon and telemetry frequencies will occupy a band only 100 kc/s wide, some means of frequency measurement is highly desirable. An ideal arrangement would be a frequency marker consisting of a 1 Mc/s crystal oscillator checked against the standard frequency transmissions from MSF or 5 or 10 Mc/s, locking a 100 kc/s multi-vibrator and harmonic generator giving an output between

ORBITING SATELLITE CARRYING AMATEUR RADIO

145 and 146 Mc/s. A word of warning is appropriate, however, as it is all too easy for the crystal and multivibrator harmonics to find their way directly into the tunable first i.f. and not come from the v.h.f. section of the receiver at all. An alternative arrangement available to listeners within 50 miles or so of London, would be to locate the Radio Society of Great Britain's beacon transmitter, GB3VHF, situated at Wrotham, Kent, and radiating on 144.5 Mc/s, and then to calibrate the first i.f. tuning range of the receiver by injecting harmonics from a 100 kc/s crystal oscillator directly into it in parallel with the output of the converter.

Unless reception is to be confined to those times when the satellite is in the immediate vicinity of the station, some form of rotatable beam aerial will be necessary. This may take the form of a four- or five-element Yagi or the more elaborate stacked multi-element Yagi.

As the satellite will not maintain a constant attitude in space, signals from its quarter-wave ground-plane aerial may arrive in any plane and either horizontal or vertical polarization of the receiving aerial could be employed.

So far as amateur signals on the two metre band are concerned, these are almost invariably horizontally polarized, and with the multi-element arrays previously mentioned the vertical polar diagram is quite narrow. This would be perfectly satisfactory for communication with the satellite at extreme range, when it would be low on the horizon, but when it is nearer, and therefore at a greater elevation, the flat-topped beam would not be working at its best. This could be important when transmitting, and some amateurs are arranging for their arrays to be steerable in elevation as well as in azimuth. Bearing in mind, however, that for the nearer passes, signals even from a 100 mW transmitter, would be many decibels above the noise level, it is not considered necessary to provide for variable elevation of the aerial when reception only is intended.

Expected Results

If Oscar III follows a similar polar orbit and at about the same height as its two predecessors, signals from it, given suitable receiving equipment, should be audible when it is at least 1,000 miles distant, which means that communication with its aid should be possible over twice that range.

The duration of signals during any pass, other things being equal, will depend upon its distance from the receiver with a maximum of about twelve minutes when the track takes it directly overhead.

It is intended that predictions of the satellite's tracks during its expected life of three to four weeks will be broadcast on Sunday mornings from the R.S.G.B. News Bulletin transmitters, GB2RS, operating the following schedule:

Frequency	Time	Location of Station
145.10 Mc/s	0930	Beaming north from London
	1000	Beaming west from London
145.80 Mc/s	1015	Beaming south from Belfast
145.30 Mc/s	1030	Beaming north west from Sutton Coldfield
	1100	Beaming south west from Sutton Coldfield
145.50 Mc/s	1130	Beaming north from Leeds
	1200	Beaming east from Leeds

It would be advisable to commence listening on the beacon frequency from five to ten minutes before the predicted time, depending upon whether the track is distant or near to the station, and as soon as this transmission is heard to start tuning the translator signal band.

* United Kingdom Co-ordinator for Project Oscar, 24 Arundel Road, Tunbridge Wells, Kent.

Miniature Selenium Rectifiers for

VOLTAGE REGULATION PROBLEMS AND THEIR SOLUTION

FOR more than a decade it has been the established practice in television receivers to obtain the e.h.t. supply for the c.r.t. by rectifying the high-voltage pulse generated by the line-scanning circuit during the rapid flyback at the end of each scanning stroke. The principles of operation of the scanning and e.h.t. circuits are well known¹ and will not be discussed here. Valve rectifiers have been universally used for the e.h.t. although selenium stacks put in a brief appearance in early days when the size of receivers was still large enough to accommodate the relatively large stacks that were necessary with the techniques of the day. Although the component space available in modern television receivers has shrunk to very small proportions, it has been possible once again to consider selenium for the e.h.t. owing to the recent introduction of very small and efficient plates. These can be stacked into compact assemblies to give sizes comparable with valves, and modern automated manufacturing processes have kept the costs down to an attractively low level. The advantages to be gained from

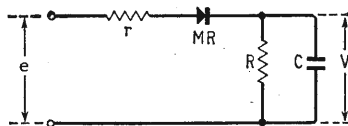

Fig. 1. Equivalent circuit of e.h.t. rectifier.

the use of a selenium stack in place of a valve are the expectation of longer life, and the elimination of a heater winding from the line transformer (with its attendant design problems, especially relevant to dual line standard sets as are now current in Great Britain). To be set against these is the inferior voltage regulation of the selenium stack, which must be carefully controlled to keep within acceptable limits of performance, and the need to limit the maximum operating temperature to a safe level.

A given percentage regulation of the e.h.t. supply yields, in any television set, a given percentage variation, in picture size for different mean picture brightness levels. This change of picture size must be kept within bounds if the set is to be acceptable to the average viewer. Subjective tests have established what level is tolerable (this is bound to vary from one person to another and a compromise must be adopted) and this therefore sets the permissible level of e.h.t. percentage regulation for any television set. This article discusses the quantitative effect of rectifier forward and reverse resistance on the voltage regulation and offers some conclusions.

The conditions applying during the reverse-biased portion of the rectifier cycle are significantly different from those that would apply in normal sine-wave rectification. These conditions are examined and certain conclusions are drawn.

Some explanation is given of the need for mounting

the rectifiers in as cool a position as is obtainable in a television receiver. The causes of uneven distribution of heating throughout the stack are given, and the remedy is given as a recommendation to add shunt capacitance across part of the stack.

Finally, conclusions are given concerning the specification and use of these rectifiers which are the subject of various patent descriptions.

Voltage Regulation

Effect of Rectifier Forward Resistance:—A simplified equivalent circuit of the e.h.t. rectifier is shown in Fig. 1 and the applied pulse waveform of voltage is illustrated in Fig. 2.

In Fig. 1, e is the instantaneous value of the input voltage, whose waveform is illustrated in Fig. 2; V is the d.c. rectified output voltage; r is the effective forward resistance of the source and of the rectifier in series; MR is an ideal rectifier of zero forward resistance and infinite reverse resistance; R is the effective load constituted by the cathode ray tube (V divided by the beam current) and C is a reservoir capacitance. R may be taken to include the shunt loading presented by the reverse resistance of a practical rectifier when reverse-biased. C is, in practice, constituted by the capacitance in the c.r.t. between the anode (internal conductive coating) and the external earthed coating.

In Fig. 2, T_1 is the duration of the first half-cycle of the oscillatory waveform that constitutes the input voltage; T_2 is the periodicity of the waveform (i.e. the reciprocal of the line frequency). Typically, the oscillatory period of a line-scan circuit is three times the line frequency, which would make $T_2 = 6T_1$. We can generalize, however, by putting $T_2 = 2nT_1$, where n is the frequency ratio. The equation of the first half-cycle of the waveform may be written as shown in Fig. 2.

If capacitor C is sufficiently large to make the time-constants rC and RC long compared with T_1 and T_2 ,

Fig. 2. Waveform of applied input.

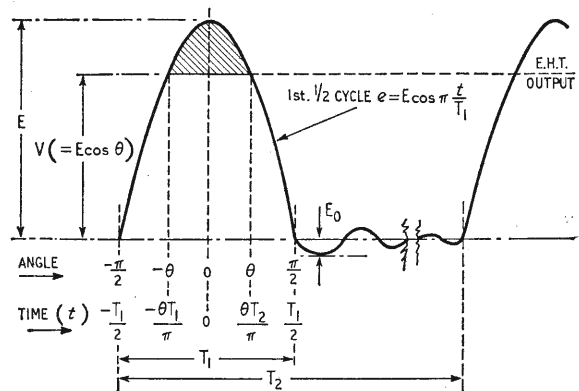

¹ See for example S.W. Amos and D.C. Birkinshaw, "Television Engineering", Vol. 4, pages 219-234. (Alternatively, W.T. Cocking, "Television Receiving Equipment", 4th edition, chapters 8 and 28). (Iliffe Books Ltd.)

Television E.H.T.

By J. L. STORR-BEST,* B.Sc.(Eng.), A.M.I.E.E.

we may assume that V remains constant throughout the cycle; that is to say, the charge injected via r into C during forward conduction of the rectifier, and the charge lost via R when the rectifier is reverse-biased, is small compared to the total charge on C . Since in practice C is of the order of 1500 pF whilst r and R are not less than 100k Ω and 100 M Ω respectively, the time-constants can be considered sufficiently long to justify this assumption.

With these conditions applying, we can see that the diode will conduct during the shaded portion of the input voltage. The current flowing from the source at any time t during this period is given by:—

$$i = \frac{I}{r} \left(E \cos \pi \frac{t}{T_1} - V \right)$$

and since $V = E \cos \theta$,

$$i = \frac{E}{r} \left(\cos \pi \frac{t}{T_1} - \cos \theta \right)$$

The energy injected into the capacitor is:—

$$\begin{aligned} & \int_{-\frac{\theta}{\pi} \cdot T_1}^{+\frac{\theta}{\pi} \cdot T_1} i \cdot V \cdot dt \\ &= \frac{E^2}{r} \int_{-\frac{\theta}{\pi} \cdot T_1}^{+\frac{\theta}{\pi} \cdot T_1} \left(\cos \pi \frac{t}{T_1} \cdot \cos \theta - \cos^2 \theta \right) \cdot dt \\ &= \frac{E^2}{r} \left[\frac{T_1}{\pi} \sin \pi \frac{t}{T_1} \cdot \cos \theta - \cos^2 \theta \cdot t \right]_{-\frac{\theta}{\pi} \cdot T_1}^{+\frac{\theta}{\pi} \cdot T_1} \\ &= \frac{E^2}{r} \left(\frac{2T_1}{\pi} \sin \theta \cos \theta - 2 \frac{\theta}{\pi} T_1 \cdot \cos^2 \theta \right) \dots (1) \end{aligned}$$

Now the energy lost from the capacitor during the complete cycle is:—

$$\begin{aligned} & \frac{V^2}{R} \times T_2 \\ &= \frac{E^2}{R} \cdot T_2 \cos^2 \theta \dots (2) \end{aligned}$$

Equating (1) and (2) we get

$$\frac{T_2^2}{R} = \frac{1}{r} \left(2 \frac{T_1}{\pi} \tan \theta - 2 \frac{T_1}{\pi} \theta \right)$$

Hence

$$\frac{r}{R} = \frac{2T_1}{\pi T_2} (\tan \theta - \theta)$$

and if, as suggested earlier, we let $T_2 = 2nT_1$ in a general case, the general solution becomes

$$\frac{r}{R} = \frac{\tan \theta - \theta}{n \cdot \pi} \dots (3)$$

Note that if we make $n = 1$, we have the condition for

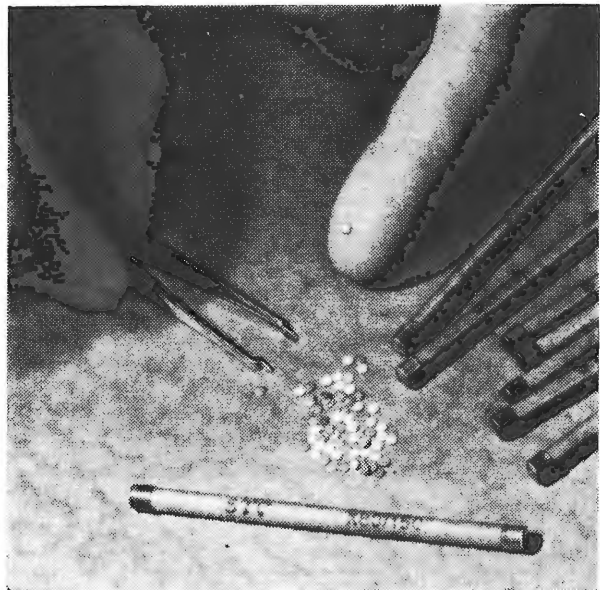

S.T.C. miniature e.h.t. rectifier elements.

normal sine wave rectification, and this provides the useful check that

$$\frac{r}{R} = \frac{\tan \theta - \theta}{\pi}, \text{ which is well-known.}^2$$

$$\text{Since } \frac{V}{E} = \cos \theta \dots \dots \dots (4)$$

we can see from equations (3) and (4) that $\frac{V}{E}$ is a

function of $\frac{r}{R}$. This relationship has been plotted in Fig. 3

for the simple sine wave case, where $n = 1$, and the typical television case where $n = 3$. It will be seen that these curves are in fact regulation characteristics, with the output voltage, V , dropping as load current $\frac{1}{R}$ is increased. The regulations of a given rectifier is *three times as bad* in the pulse rectification case, as it is in the sine-wave case. Matters look even worse when we compare the regulation of this pulse rectifier circuit to the equivalent d.c. case. Thus, the value of $\frac{r}{R}$ for 95% output must be 44 times smaller than in a d.c. circuit; in other words, a 100k Ω series resistance measured by d.c. appears as a source resistance of 4.4 M Ω in the pulse rectifier circuit!

How bad a regulation can be tolerated and what does this mean in terms of specifying the forward characteristic of the rectifier? To answer these questions, first let us look at the effect of e.h.t. voltage regulation on television receiver behaviour, as seen by the viewer.

The spot deflection in a magnetically-deflected c.r.t. beam is given by $D = \frac{K \cdot B}{\sqrt{V}}$ where K is a constant dependent on the tube and deflection coil geometry, B is the deflecting flux density and E is the e.h.t. voltage.

*STC Semiconductor Division (Rectifiers)

²M. G. Scroggie, "The Diode Rectifier in Valve Voltmeters", *Wireless World*, July, 1954.

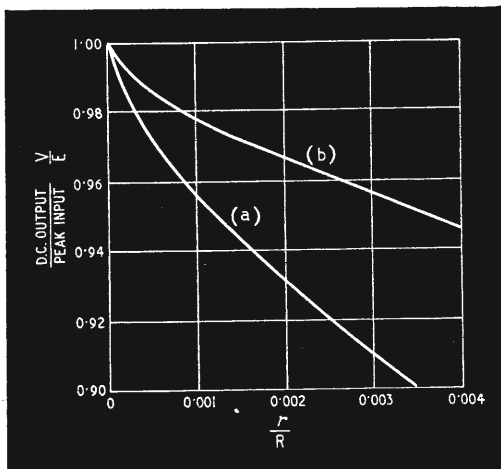

Fig. 3. Comparison of theoretical regulation curves obtained with the same rectifier for (a) TV pulse rectifier ($n = 3$): (b) normal half sine wave rectifier ($n = 1$).

Thus for a given current through the deflection coils, and hence for a given flux density, the deflection varies inversely as the square root of the e.h.t. In practical terms this means that, as the brilliance control is advanced and more beam current is drawn, the resulting drop in e.h.t. due to the voltage regulation of the rectifier system causes the picture to expand. If we neglect the effect of the change in rectifier load on the deflection scanning circuit, then a 5% drop in e.h.t. gives approximately a $2\frac{1}{2}\%$ increase in picture width (and height). On a 20-in screen, this amounts to about $\frac{1}{2}$ in increase in the diagonal.

It is convenient to define the voltage regulation in terms of an effective d.c. source resistance. For example, it has been found by subjective viewing tests that a performance which is just acceptable is given by an effective source resistance of $8\text{M}\Omega$ for a change in beam current from zero to $100\ \mu\text{A}$. The interpretation of the "8 MΩ" is that the voltage drop from no load to 100 microamps is $(8 \times 10^6) \times (100 \times 10^{-6}) = 800\ \text{V}$. This constitutes a 5% regulation on a 16 kV e.h.t. supply.

We can now begin to see what the maximum forward resistance of the rectifier must be.

$$\begin{aligned} \text{Thus e.h.t. on no load} &= 16\ \text{kV} \\ \text{e.h.t. on } 100\ \mu\text{A} &= 15.2\ \text{kV} \\ R &= \frac{15.2 \times 10^3}{100 \times 10^{-6}} \approx 150\ \text{M}\Omega \end{aligned}$$

$$\text{Since } \frac{V}{E} = \frac{15.2}{16} = 0.95$$

$$\theta = \cos^{-1} 0.95 = 0.3176$$

$$\therefore \frac{r}{R} = \frac{\tan \theta - \theta}{n\pi} = \frac{0.3288 - 0.3176}{3\pi} \quad (\text{if } n = 3)$$

$$= 0.00119$$

$$\begin{aligned} \therefore r &= 0.00119 \times 150\ \text{M}\Omega \\ &= 180\ \text{k}\Omega \end{aligned}$$

Thus a forward slope resistance of 180 kΩ yields an effective regulation resistance of $8\ \text{M}\Omega$. The peak current through the rectifier is $800/180 = 4.4\ \text{mA}$.

Effect of Rectifier Reverse Resistance:—During the period of the cycle in which the diode is not conducting the capacitor C loses charge both through the beam current path ($150\ \text{M}\Omega$ in the above example) and through the leakage path of the reverse-biased diode. Thus if,

for example, the diode leakage current is $50\ \mu\text{A}$, we have in shunt with the $150\ \text{M}\Omega$ an effective resistance of

$$\frac{15.2 \times 10^3}{50 \times 10^{-6}} \approx 300\ \text{M}\Omega$$

Thus R becomes $\frac{150 \times 300}{450} = 100\ \text{M}\Omega$ for a load current of $100\ \mu\text{A}$.

For zero load current R is simply the $300\ \text{M}\Omega$ due to reverse leakage current.

$$\therefore \text{At zero, } \frac{r}{R} = \frac{180\text{k}\Omega}{300\text{M}\Omega} = 0.0006, \text{ from which } \frac{V}{E} = 0.968$$

$$\text{At } 100\ \mu\text{A, } \frac{r}{R} = \frac{180\text{k}\Omega}{100\text{M}\Omega} = 0.0018, \text{ from which}$$

$$\frac{V}{E} = 0.933$$

Hence the voltage drop from 0 to $100\ \mu\text{A}$ is $\frac{16(0.968 - 0.933)\ \text{kV}}{16} = 560\ \text{V}$.

Thus the effect of the presence of this finite rectifier reverse resistance is to improve the regulation resistance from $8\ \text{M}\Omega$ to $5.6\ \text{M}\Omega$. On the other hand, the e.h.t. output is of course lower than it would have been in the absence of leakage current. The no load output is approximately 15.5 kV instead of 16 kV, and the $100\ \mu\text{A}$ load output is about 14.9 kV instead of 15.2 kV.

The conditions applying during the reverse-biased portion of the cycle are, in practice, complicated by the presence of shunt capacitance to earth, distributed down the length of the rectifier stack. The effect of this is to give a gradient of reverse voltage per plate rising to a peak at the pulse input end of the stack. This effect, and the remedy, is discussed later.

It has been shown that to obtain the acceptable figure of $8\ \text{M}\Omega$ regulation resistance requires a total forward resistance (source + rectifier) of $180\text{k}\Omega$. Now the source will generally constitute a significant part of this $180\text{k}\Omega$, depending on the design of the line output stage and transformer. In one practical case on which measurements were made, the regulation due to the source alone (i.e. measured with a valve rectifier) was $6\ \text{M}\Omega$ and, in an improved design†, $3\ \text{M}\Omega$. In the former case, the $6\ \text{M}\Omega$ is equivalent to $110\text{k}\Omega$, so that only $70\text{k}\Omega$ is left for the rectifiers. It is found that with the quality of 2-mm plates at present available, it is not possible to obtain such a low forward resistance whilst having sufficient plates to withstand the maximum reverse voltage.

Conclusion 1. 2-mm selenium e.h.t. stacks can only be used in television sets in which the line output stage (and transformer) design is good enough. To check whether this is so, the e.h.t. regulation should be measured between 0 and $100\ \mu\text{A}$, using a valve rectifier. If the regulation resistance, measured in this way, exceeds about 3 or $4\ \text{M}\Omega$, it will be impossible to use a 2-mm selenium stack rectifier and obtain an acceptable regulation.

Fig. 4 illustrates the measured forward characteristic of a selenium stack containing 170 2-mm. plates. The characteristic may be approximated by the dotted straight line. This line, in turn, represents the forward characteristic of a perfect rectifier of zero forward resistance, in series with a resistance of a perfect rectifier of zero forward resistance, in series with a resistance of $45\text{k}\Omega$. Thus, three of these in series (which may be necessary to withstand a certain required reverse voltage) will be equivalent to a bias voltage of 360V. in series with $135\text{k}\Omega$.

† The new Thorn miniature jellypot line transformer

The 360V is significant only in that it imposes a fixed voltage drop at all load currents; on the other hand, as already discussed, the 135k Ω determines the *voltage regulation*. A practical test was carried out with three such rectifiers, working from an output stage and transformer of 3 M Ω regulation (measured as described above). Now 3 M Ω regulation resistance is equivalent to 40k Ω series source resistance, calculated by the methods described. Therefore the combined series resistance of source and rectifier should be about 185k Ω , it will be remembered that a 180k Ω series resistance yields, by calculation, an 8 M Ω regulation resistance if no leakage current is present. In the measured case, these three rectifier stacks gave a regulation resistance of 10 M Ω , which is a reasonable correlation considering the assumptions that have been made. The numerical illustrations are chiefly of use in obtaining an understanding of the dependence of rectifier performance on certain parameters rather than of yielding specification data. Once the former is understood, the latter can be fixed experimentally with a high degree of confidence.

The addition of 10 pF capacitance across one of the stacks (for a reason to be discussed later) had the effect of worsening the regulation resistance from 10 to 16 M Ω . The explanation of this effect is not complete, but it is known from many practical observations that the addition of shunt capacitance always worsens the regulation.

It was concluded that these 170-plate rectifier stacks would not be satisfactory for television e.h.t. owing to the excessive regulation resistance produced, particularly when the necessary shunt capacitance was added. At the same time, it would not be possible to reduce greatly the number of plates whilst still being able to withstand the absolute maximum reverse voltage; if the reverse voltage per plate is allowed to become too great, the rise in leakage current may be too great for safe operation and the reduced level of e.h.t. may become unacceptable.

A suitable compromise can be made with a reduced number of plates per stack. For example, a 150-plate stack will reduce the regulation resistance, including the effect of added shunt capacitance, to about 9 M Ω . In this case, improvement to the specification figure of 8 M Ω can be met by control of plate forward characteristic. This is the basis of the present design.

Conclusion 2. To obtain a regulation resistance not exceeding 8 M Ω from 0 to 100 μ A (on a nominal 16 kV d.c. output) three stacks with 150 plates each should be used. (This does not mean that the current is limited to 100 μ A nor the d.c. output of 16 kV.

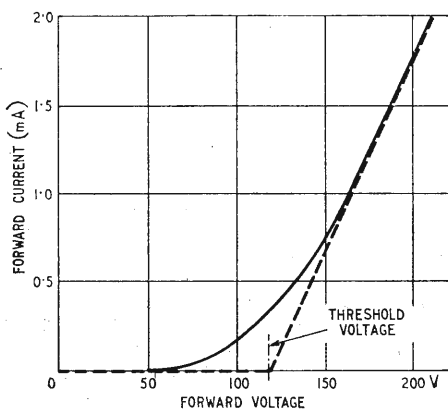

Fig. 4. Measured forward characteristic of a typical 170-plate 2-mm selenium stack.

It is merely an assessment of the requirements for voltage regulation.)

Reverse Voltage

The main difference between the reverse voltage conditions of a pulsed e.h.t. rectifier and that of a sinusoidal e.h.t. rectifier may be summarized as follows. The peak inverse voltage (p.i.v.) of a pulsed input rectifier may be only a small percentage above the d.c. output voltage, whereas for a sinusoidal input, the p.i.v. is at least twice the d.c. output. (In Fig. 2 it will be seen that the p.i.v. is $V + E_0$, which would approach $E + E_0$ on zero beam current and with zero leakage rectifiers.) To be set against this advantage of a lower p.i.v. per d.c. volt, is the disadvantage that the reverse voltage persists for a much larger percentage of the cycle; with a sinusoidal input, only during a very small portion of the cycle is the reverse voltage at a high level (around the peak of the sinewave); with the pulse input, d.c. blocking conditions almost apply.

As shown earlier there is another disadvantage in the pulse input compared with the sinusoidal input: the voltage regulation of a given stack is worse by the ratio of equivalent pulse frequency to line frequency; i.e. if the line scan transformer circuit resonates at three times the line scan frequency, then the regulation of the rectifier will be three times as bad as it would be when fed with a sine-wave input at line frequency. This is partly offset by the lower p.i.v. and therefore by the reduced number of plates in use; however, to achieve equally as good a regulation as with sinusoidal input, it would be necessary to use even less plates, and hence to end up with a requirement for a greater p.i.v. per plate.

The actual p.i.v. quoted for a particular stack is largely a matter of definition: the principles have been explained above. Thus, the p.i.v. for pulse rectification will actually be *lower* than for sinusoidal operation because of the "blocking" duty performed, as previously explained. Sinusoidal ratings, on the other hand, tend to be conservative since they are intended for a wide variety of general applications. A further consideration is that the pulse rating, for the particular application of television line flyback pulses, must be made as keen as possible in order to be able to achieve at all necessary compromise between voltage regulation and p.i.v. For this reason it is considered that a single p.i.v. rating can be given for both sinusoidal and television pulse inputs. The d.c. rating should of course be lower than this figure, as mentioned above.

The ratings adopted for the present rectifier stack designs are as follows:—

150-plate stack Code X80/150. D.c. reverse voltage at 20 μ A:—6000 V. (40V/plate). P.i.v. sinusoidal or t.v. pulse input :—6750V. (45V/plate). Stacks with other numbers of plates may be rated accordingly.

Rectifier Heating

Causes:—As in most rectifiers, heating is due to forward conduction, in which power is dissipated by a high current at low voltage; or to reverse leakage, by which power is dissipated by low currents at high voltage.

Some idea of dissipation can be obtained by re-examining Figs. 1 and 2 and working out an example. Figures that will not be far from those of a practical case, and are convenient to use, are as follows:—

Source resistance = 40k Ω (Corresponds to a 3 M Ω regulation resistance)
 Stacks used = 3 \times 150-plate

Forward resistance total = 120kΩ (Cf. Fig. 4 for a single 170-plate stack)

Total forward threshold voltage = 315V
 Leakage current, total = 30 μA
 Peak input voltage = 16 kV
 Stray capacitance = Zero (to reduce complexity of analysis)

The *forward dissipation* is given by integrating the product of diode forward current and voltage over the conducting portion of the cycle. In Fig. 5, which takes into account the rectifier "threshold" voltage, the shaded area represents conduction. V is the d.c. rectified voltage and V_d is the rectified "threshold voltage" (corresponding to the horizontal intercept of the straight dotted line in Fig. 4). Conduction starts when the input voltage exceeds the d.c. + the threshold voltage.

The voltage across the rectifier during conduction = $e - V$

= $E \cos \pi \frac{t}{T_1} - a.E \cos \theta$ (if V is some fraction a of the combined voltage ($V + V_d$)).

$$= E \left(\cos \pi \frac{t}{T_1} - a \cos \theta \right)$$

The current through the rectifier = $\frac{e - (V + V_d)}{r}$

$$= \frac{E}{\gamma} \left(\cos \pi \frac{t}{T_1} - \cos \theta \right)$$

The energy dissipated per pulse of conduction is given by

$$J = \frac{E^2}{\gamma} \int_{-\frac{\theta T_1}{\pi}}^{+\frac{\theta T_1}{\pi}} \left(\cos \pi \frac{t}{T_1} - \cos \theta \right) \cdot \left(\cos \pi \frac{t}{T_1} - a \cdot \cos \theta \right) dt$$

$$\therefore J = \frac{E^2}{\gamma} \cdot \frac{T_1}{2\pi} [2\theta(1 + 2a \cos^2 \theta) - (1 + 2a) \sin 2\theta]$$

Therefore if W is the mean power dissipation due to forward conduction

$$W \times T_2 = J$$

or $W \times nT_1 = J$ (using the symbol n as before)

$$\therefore W = \frac{J}{nT_1}$$

$$= \frac{E^2}{r} \cdot \frac{1}{2n\pi} [2\theta(1 + 2a \cos^2 \theta) - (1 + 2a) \sin 2\theta]$$

In the practical case given, the following figures are calculated between 0 and 500 μA load (beam) current.

Beam Current (μA)	E.H.T. (kV)	Peak rectifier current (mA)	Forward power dissipation
0	15.35	2.1	50 mW
100	14.8	5.5	340 mW
300	14.1	10.0	950 mW
500	13.6	13.1	1.9 W

Now the *reverse* dissipation is approximately constant at about 15 kV × 30 μA = 450 mW if we neglect the rise of leakage current due to the forward heating of the stack.

Therefore we can roughly say that at the normal picture setting, which corresponds to a little over 100 μA, the forward and reverse losses contribute fairly equally. At extreme brightness, or with a worn c.r.t., the forward losses will contribute most to the heating.

These calculations only give a guide to the conditions and give a feel for the order of power involved. In

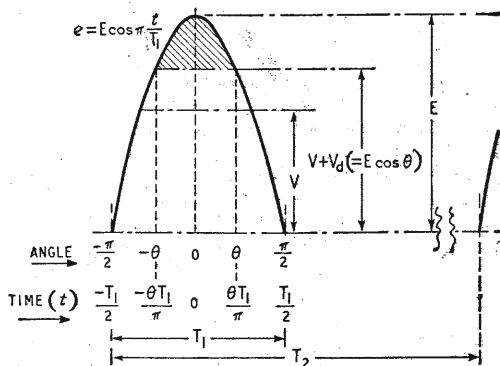

Fig. 5. Basis for calculating forward dissipation.

practice, they will be modified for a number of reasons. The most important of these is probably the fact that extra reverse leakage current must flow, particularly in the plates nearest the pulse input, in order to charge up the stray capacitance to earth. At the relatively high frequencies involved in 625-line receivers, this current can be appreciable. It leads in fact to a marked temperature gradient over the length of the complete stack assembly, and precautions have to be taken to even this out in order to avoid overstressing the first stack. The effect may be analysed by regarding the reverse-biased rectifier assembly as a transmission line consisting of series and shunt capacitances; the series elements are the effective capacitances of the rectifier plates, and the shunt ones are the stray capacitances to earth. Such an analysis shows that the voltage gradient may be reduced by increasing the ratio of series-to-shunt capacitance, and hence reducing the proportion of the transmitted current that is lost by "earth-capacity leakage" at each plate junction. It is not possible in this case to apply the suggested method literally, i.e., by adding shunt capacitance across each plate, or even across each stack of plates; this would increase the total stack capacitance, and hence the capacitance across the tuned line transformer; since the latter has an extremely high L/C ratio, very little extra capacitance can be tolerated. The solution** was to apply a small amount of shunt capacitance across just the first stack of the three. The effective input capacitance was then not increased beyond the value of two of the stacks in series. By a proper choice of capacitance value it was possible to find a condition in which the heating of the first stack could be brought down to equality with the other two. A value of 10 pF was found to be about optimum.

Finally, whilst discussing the causes of rectifier heating, the ambient temperature cannot be overlooked. The position which the rectifier is required to occupy for functional reasons is perhaps the worst in the set; this is because the line output valve carries a very heavy dissipation and because the assembly must be properly screened to reduce radiation. Particular care must therefore be taken to keep the ambient temperature within bounds.

Recommendations

(1) The stack should not normally be expected to deliver more than 300 μA d.c. to the load. This should be ample for the requirements of television monochrome receivers, and short-period excesses may not be harmful.

(2) A 10-pF capacitor of adequate working voltage, should be shunted across the first rectifier of a stack of three to even out the temperature gradient of the three stacks. This value may not be optimum for all con-

** Br. Pat. Application No 38622/63

ditions, and layout variations that appreciably affect shunt capacitance may require the value to be modified. With a different number of stacks the same principles will apply and an optimum should be found experimentally.

(3) The temperature surrounding the stack, after normal stabilization, should not be allowed to exceed 50°C.

General Conclusions

If properly used, 2-mm h.v. selenium stacks may be chosen with advantage as a substitute for a valve rectifier in the line flyback e.h.t. circuit of television receivers. The advantages to be expected are a longer life and the reduction of cost, size and complexity of the line scan output transformer by the elimination of the valve heater winding.

The voltage regulation of a television e.h.t. supply determines the extent to which picture size varies with brilliance. Selenium rectifiers give a poorer regulated supply than valve rectifiers and can only be used in this application if the regulation of the line output stage (including transformer) is already good. This should be checked, using a valve rectifier. (If no heater winding is available on the transformer, a battery supply can be used for the test.) The e.h.t. voltage should not drop by more than 400V, and preferably not more than 300V, when the c.r.t. beam current is increased from zero to 100 μ A. (300V drop at 100 μ A corresponds to a 3M Ω "regulation resistance".) If the line output circuit gives a worse regulation than this with a valve rectifier, there is little hope that the performance will be acceptable with a 2-mm selenium stack rectifier. (The ultimate criterion is a subjective test to judge the degree of viewer annoyance caused by the change of picture size when the brilliance control is adjusted from a black to a fully bright picture.) Measurement of "regulation resistance" should always be made with the line oscillator running at the correct line frequency, preferably synchronized.

Three similar stacks in series are generally needed for the normal level of e.h.t. found in ordinary domestic monochrome receivers. The number of plates to be specified per stack should be matched to the maximum p.i.v. expected from the type of receiver to be used, with the controls set for normal operation. (The p.i.v. for this purpose should be taken as the voltage amplitude between the crest of the positive voltage pulse applied to the rectifier and the trough of the first negative overshoot pulse.) If the number of plates is made greater than necessary, the voltage regulation may suffer; if too small, the rectifier may overheat due to overvoltage per plate in reverse. A figure of 45V reverse per plate should be used for this estimation. On a d.c. test, the voltage expected should not be less than 40V per plate at 20 microamps.

A small capacitor, of appropriate working voltage, should be connected in shunt with the stack nearest to the pulse input. The value of this capacitor will be of the order of 10pF; an optimum value may be chosen by selecting one such that the heating of the first stack is no greater than that of the other two. (With zero capacitance, the first stack may overheat; with too great a capacitance, the first stack may be "bypassed" and stay cold whilst the other two carry the full burden and overheat.) Since this bypass capacitor is to compensate for the effect of stray earth capacitance, the optimum value may be expected to vary with circuit layout.

The stacks should not, under normal working conditions, be permitted to deliver more than 300 μ A d.c. into the load. This should be perfectly adequate for monochrome receivers. Currents up to twice this amount will not, however, cause catastrophic failure.

Whilst it is necessary, by virtue of its functional position in the set, for the rectifier to work in a high temperature area (e.g., near the heavily dissipating line output valve) every effort should be made to keep the surrounding temperature as low as possible. In any case, this temperature must not be allowed to exceed 50°C. This may call for some ingenuity in set design since close screening will almost certainly be used in this area to reduce radiation. This problem can, however, be solved without great expense in practical receivers by appropriate positioning of the rectifiers and by making adequate ventilation arrangements.

Acknowledgements:—The development work on the selenium rectifiers for this application was carried out with the co-operation of the Thorn Television Laboratories, whose assistance has been much appreciated. Finally, the author would like to thank the management of Standard Telephones and Cables Limited for permission to publish this article.

Addendum:—It is worth recording that since the first draft of this article was prepared, significant improvements to the design and manufacturing techniques of these rectifiers have been made. In particular, these have led to a marked reduction of forward losses and a consequent improvement in voltage regulation characteristics. With the earlier designs, on which numerical examples in the article are based, the number of plates had to be chosen as a narrow compromise between p.i.v. and voltage regulation performance. The quality of current rectifiers is now, however, such that there is a good working margin between acceptable limits for these two parameters.

Fig. 6 gives a comparative illustration of the forward characteristics of a typical 150 plate rectifier of to-day compared with one of a year ago. (Fig. 4 of the article shows a 170 plate rectifier of this earlier period.) It will be seen that the forward slope has considerably improved, i.e., the slope resistance is lower, and that the effective threshold voltage is lower. Voltage regulation resistance, including the contribution from the Thorn jellypot transformer, is now typically only 5M Ω from 0 to 100 μ A beam current; subjective viewer tests have shown this to be a very worthwhile improvement in performance as regards picture size variation with brilliance control setting.

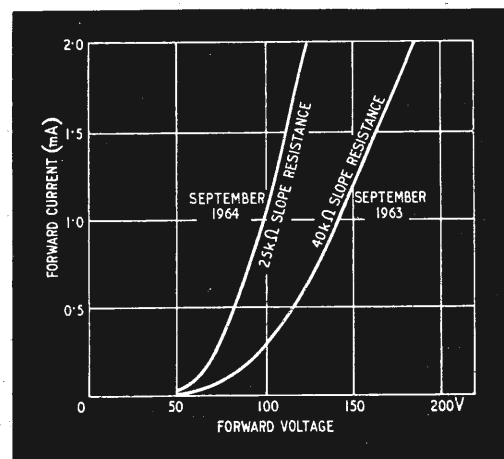

Fig. 6. Comparison between the measured forward characteristics of typical 150-plate miniature selenium e.h.t. rectifiers (Type X80/150) showing improved performance of present production.

Monostable Blocking Oscillator

HIGH-POWER, FAST PULSES FROM TWO TRANSISTORS

By M. D. A. B. RACKOWE,* B.A.

SOME simple blocking oscillator monostable circuits are known¹ which produce pulses of good shape, but relatively low power. If these pulses are then amplified by a power amplifier, the pulse shape is liable to deteriorate unless rather elaborate circuitry is used. In the circuit described here, the power amplifier is included in the positive feedback loop, and peak powers of the order of 1 watt may be obtained using a very simple two-transistor circuit.

Description of Circuit

When the circuit shown in Fig. 1 is in its stable state transistors T1 and T2 are both cut off, the base/emitter junction of T1 being reverse biased by the potential divider in its emitter circuit. The application of a positive triggering pulse via the input differentiating network to the base of T1 overcomes the reverse bias and causes collector current to flow in T1. This is directly coupled to the base of T2, which therefore turns on. A voltage is induced in the secondary of the output transformer, which is connected to T1 emitter in such a way that the emitter is driven negative. Thus T1 is driven further into conduction, since its base is clamped by a diode. This regenerative action means that T2 turns on very rapidly, giving the output pulse a fast leading edge. Conduction proceeds until capacitor C has charged to such a voltage that T1 base/emitter junction is no longer forward biased. T1 collector current now falls, and the regenerative action takes place in reverse, ensuring a rapid turn off.

The resistor in the emitter of T2 is merely to prevent thermal runaway. The amplitude of the output pulses depends on the supply voltage, and the primary/output winding turns ratio of the transformer.

Pulse Duration

Consider the circuit in its stable state. The supply voltage is $-V$ volts, and the potential at T1 emitter with respect to the negative supply is

$$\frac{R_1 V}{R_1 + R_2} \approx \frac{R_1}{R_2} V \text{ if } R_1 \ll R_2$$

Suppose a positive pulse is now applied at the input. Regenerative action takes place and T2 bottoms. A step of V volts occurs in the transformer primary, and a voltage of $N_3 V/N_1$ in the secondary.

The potential at T1 emitter is now

$$\frac{R_1}{R_2} V - \frac{N_3}{N_1} V$$

The capacitor C now charges until the potential at T1

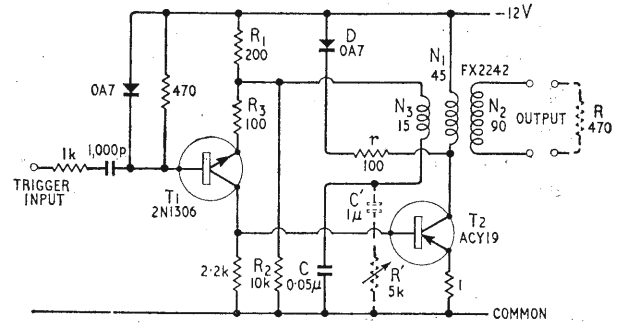

Fig. 1. Circuit of blocking oscillator. Components shown dotted control pulse duration.

emitter reaches $-V_{BE}$, whereupon T1 cuts off, marking the end of the pulse.

The time taken by C to charge from $V(R_1/R_2 - N_3/N_1)$ to $-V_{BE}$ is therefore the pulse duration.

The charging current for C flows through both R_3 and the potential divider formed by R_1 and R_2 . Fig. 2 shows the equivalent charging circuit for the duration of the pulse.

Consider the instantaneous voltage v across C. By Thévenin's theorem, the contribution due to R_1 is $R_3/(R_1 + R_3) \cdot VN_3/N_1(1 - e^{-t/RC})$ where R is the parallel combination of R_1 and $R_3 = R_1 R_3 / (R_1 + R_3)$.

The contribution due to R_3 is

$$\frac{R_1}{R_1 + R_3} \cdot \left(V \frac{N_3}{N_1} - V \frac{R_1}{R_2} - V_{BE} \right) \left(1 - e^{-t/RC} \right)$$

$$\therefore v = \left(V \frac{N_3}{N_1} - K \right) \left(1 - e^{-t/RC} \right)$$

$$\text{where } K = \frac{R_1}{R_1 + R_3} \left(V \frac{R_1}{R_2} - V_{BE} \right)$$

$$\text{T1 turns off when } v = -V_{BE} - V \left(\frac{R_1}{R_2} - \frac{N_3}{N_1} \right)$$

$$\text{or } \left(V \frac{N_3}{N_1} - K \right) \left(1 - e^{-t/RC} \right) = -V_{BE} - V \left(\frac{R_1}{R_2} - \frac{N_3}{N_1} \right)$$

$$\therefore e^{-t/RC} = \left(\frac{V_{BE} + VR_1/R_2 - K}{VN_3/N_1 - K} \right)$$

$$\therefore t = RC \log \left(\frac{VN_3/N_1 - K}{V_{BE} + VR_1/R_2 - K} \right)$$

At the end of the pulse C discharges through R_1 and R_2 , and this time constant must be kept short, so that C is fully discharged before the next pulse is required.

* AMF British Research Lab. (now with Coutant Electronics)

¹ "Functional Circuits and Oscillators," H. J. Reich, (Van Nostrand, 1961.)

Maximum Repetition Frequency

If the load across the output winding is R_L , then the load reflected into the primary is $R_L N_1^2/N_2^2$.

If this is large compared with the emitter resistor, then the maximum current $I = V/R_L(N_1/N_2)^2$.

At the end of the pulse, energy stored in the transformer primary inductance L is $\frac{1}{2} LI^2$. As the induced voltage goes negative with respect to V , the resistor r in series with the catching diode D appears in parallel with the load reflected into the primary winding. Thus the effective resistance is

$$\frac{r R_L (N_1/N_2)^2}{r + R_L (N_1/N_2)^2}$$

The reverse voltage transient therefore has the value

$$\frac{IrR_L}{r \left(\frac{N_2}{N_1} \right)^2 + R_L} = \frac{Vr}{r + \left(\frac{N_1}{N_3} \right)^2 R_L}$$

The rate at which the voltage decays is given by the formula

$$v = \frac{Vr}{r + \left(\frac{N_1}{N_2} \right)^2 R_L} \exp \left[- \frac{L}{rR_L} \left(r \left(\frac{N_2}{N_1} \right)^2 + R_L \right) t \right]$$

This determines the maximum p.r.f. at which the circuit may be used, since the reverse voltage must fall to a low value, before the circuit can again be triggered.

Triggering

In order to trigger the monostable, the trigger pulse must have sufficient amplitude to forward bias T1. The reverse bias of the emitter is $VR_1/R_2 + V_{BE}$.

It is also required that after the trigger pulse is removed, the loop gain of the circuit should be greater than unity. In the section on pulse duration it was found that the feedback winding develops a voltage VN_3/N_1 . Current flowing in R_3 is therefore $(VN_3/N_1 - VR_1/R_2 - V_{BE})/R_3$.

This current flows in T1 collector, and if the effective current gain of T2 is β , then the transformer primary current is $\beta/R_3 (VN_3/N_1 - VR_1/R_2 - V_{BE})$.

In the last section it was found that the primary current actually flowing is $V/R_2 (N_1/N_2)^2$. Therefore the loop gain is

$$\frac{\beta R_2 (N_2/N_1)^2}{VR_3} \left(V \frac{N_3}{N_1} - V \frac{R_1}{R_2} - V_{BE} \right)$$

The power P delivered to the load is $\frac{V^2}{R_2} \left(\frac{N_1}{N_2} \right)^2$

so the loop gain in terms of power is

$$\frac{\beta V}{PR_3} \left(V \frac{N_3}{N_1} - V \frac{R_1}{R_2} - V_{BE} \right)$$

It would appear, therefore, that for a given loop gain the power output can be increased if R_3 is reduced or N_3/N_1 increased. These terms, however, govern the power required by the feedback circuit, which must be subtracted from the available output power.

Control of Pulse Duration

It was seen earlier that pulse duration can be controlled by varying R_1 , R_2 , R_3 or C . Since R_1 and R_2 affect the d.c. levels in the circuit and R_3 affects the loop gain, it is most convenient to vary C . If a continuously variable

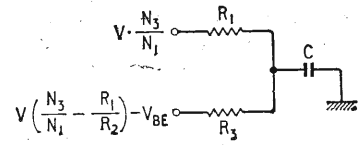

Fig. 2. Equivalent charging circuit of C .

control is required, the components of R' and C' , shown dotted in the diagram, are added. Minimum pulse duration is determined by C and maximum duration by C' . If C is made very small, the transit times become a significant proportion of the total pulse time, and the pulse tends towards a spike. Rise and fall times can be improved by using fast transistors, but it is also necessary to reduce the size of the pulse transformer, in order to minimise losses, and winding capacity. However, the size of the transformer also governs the maximum pulse duration available, since if it is small and therefore has time to saturate, the pulse will have a marked droop. It was found in practice that a width ratio of 20:1 was quite readily attainable.

Practical Design

Fig. 2 shows the component values used in a practical circuit.

The primary/output winding turns ratio of the transformer gives a 2:1 step up in voltage. Since a 12-volt power supply is used, the output pulses have an amplitude of 24 volts, which is delivered into a 470 Ω load. Output power during each pulse is therefore 1.2 W.

The values of C and C' give a range of pulse widths between 10 μ sec. and 200 μ sec., continuous control being obtained by means of the 5k Ω variable resistor in series with C .

At minimum pulse width the maximum repetition frequency is 25 kc/s, and at maximum pulse width it is 2 kc/s. For continuous operation at a high duty cycle, the output transistor should be mounted on a heat sink.

Conclusion

This type of circuit affords a simple means of obtaining medium-power pulses. If pulses of higher power than this are required, the loop gain must be maintained by increasing the effective current gain of the output transistor. This can be simply achieved by including an emitter follower between T1 and T2. The circuit has been found particularly useful for firing s.c.r.'s where a number of these devices have to be triggered at the same time.

INFORMATION SERVICE FOR PROFESSIONAL READERS

To expedite requests for further information on products appearing in the editorial and advertisement pages of *Wireless World* each month, a sheet of reader service cards is included in this issue. The cards will be found between advertisement pages 16 and 19.

We invite readers to make use of these cards for all inquiries dealing with specific products. Many editorial items and all advertisements are coded with a number, prefixed by 16WWW, and it is then necessary only to enter the number(s) on the card.

Readers will appreciate the advantage of being able to fold out the sheet of cards, enabling them to make entries while studying the editorial and advertisement pages.

Postage is free in the U.K., but cards must be stamped if posted overseas. This service will enable professional readers to obtain the additional information they require quickly and easily.

UNITS

By "CATHODE RAY"

I SUSPECT that most people in our line reckon the subject of units is pretty boring. It may look like a side issue, all right for a few specialists to get on with, but of no great practical value. Or, if one does glance into the history, its murky and confusing appearance discourages further investigation.

There certainly is a long and tangled history, which like most things has been speeding up lately. The progress made in the last few years has been so great that those whose student days are well behind may need a little refresher. After all, getting our sums right is of great practical value, and without clear ideas about units it is quite easy to get them wrong. And as for the more distant history, that is really quite fascinating. The French Revolution might not seem particularly relevant for us—and anyway, didn't it show its contempt for science by sending to the guillotine Lavoisier, one of the greatest scientists of his time, who devised the first systematic chemical notation, in use to this day? Yet paradoxically it initiated the metric system, which also is in use to this day. That was by far the biggest step forward in the whole progress of units, because it was something quite new and it provided the basis of the system that has become universally adopted for science (and, in an increasing number of countries, for every purpose).

International System

This present-day system of units is known officially as SI (Système Internationale d'Unités). It is an extension of the m.k.s. system, which itself was based on the metric system.

You may perhaps be thinking that we have only just changed over to the m.k.s. system—with an effort—and why should this SI appear so soon? Some pockets of c.g.s. resistance, such as the magnet industry, haven't even got as far as the m.k.s. system and will feel doubly injured. So let us take a broad look at the reasons for these changes.

Obviously for every kind of trade there is a need for units of quantity. And to establish confidence, the quantities represented by those units should be generally agreed; they must be the same for buyers and sellers. In the early days, when trade was mostly quite local, each district had its own units. And there was a tendency, not yet extinct, for each trade to have its own units. And so we still have a difference of more than a pint between the American and British gallons to cause confusion in car performance figures and cookery recipes. And there are innumerable trade measures such as crans, pipes, pecks, barrels (of different sizes), bundles and trusses. Now that trade as well as science and technology is world-wide, there can surely be no doubt that the ideal is one and only one basic system of units for all purposes everywhere.

Every unit must be realized in some physical standard. Our unit of length, the foot, was originally the length of an adult human foot; but while this standard had the advantage of being plentifully distributed there was the obvious disadvantage of imprecision. With the increasing need for accuracy there began the practice of establishing

one carefully preserved standard, of which all others were copies; and so the foot is now one-third of the distance between two marks on a bronze standard yard.

Clearly the units of a lot of quantities can be derived from others. There is no need to have independent standards of area and volume, since unit area can so easily be defined as the area enclosed by a square of unit length of side, and so on. One great advance made in 1790 with the invention of the metric system was to reduce the independent units to two—length and time—and to base them not on arbitrary man-made standards but on the earth itself. So the standard of length, the metre, was defined as one ten-millionth of the distance from pole to equator along the meridian through Paris, and the second was 1/86,400 of a day. The unit of mass (the gramme) was tied to that of length and the density of water by defining it as the mass of a cubic centimetre of water at normal atmospheric pressure and the temperature of maximum density.

Although the standard of mass was defined in terms of length and the properties of a natural product, mass is quite different in kind from length and time, so the metric system is regarded as based on three fundamental quantities. Other quantities such as velocity and force can be derived from these.

Another valuable innovation of the metric system was that all multiples and subdivisions (except those of time, which presumably were considered too well established and already universal) were to be decimal. So the metric system is much easier to learn than our "12 inches one foot, 3 feet one yard," etc. notwithstanding that "5½ yards one rod, pole or perch" has recently been abolished.

Mass and Weight

At this point we ought to take note of the confusion of thought that often exists with regard to mass and weight. The Weights and Measures Act of 1878 defines the pound as the weight of a certain piece of platinum and declares it to be "the standard measure of Weight and of measure having reference to weight." Now if that piece of platinum was really a standard of weight there would need to be some reference in the Act to *where* it was. Weight is a force that depends on gravitational attraction, which varies between different places on the earth's surface—to say nothing of spaceships. One can be quite sure that what was in the minds of those who worded the Act was not a force but a quantity of material, for which the correct word is mass. When you buy a pound of sugar it is the quantity of sugar you are interested in, not its weight. A pound (mass) of sugar is just as nutritious in orbit, where its weight is nil, as on the ground. So although the word "weight" occurs seven times in our legal definition of a pound and "mass" not at all, it really defines a unit of mass, just like the original cubic centimetre (gramme) of water in the metric system or the kilogramme of metal which became its actual embodiment. But because it happens that at any given point the force of gravity (i.e., the weight) is directly proportional to mass, the practical method of comparing masses is by weight. If the force on a bag of sugar is shown by a balance to be the same as that on a piece of iron marked

"2 lb," the mass of the sugar is thereby shown to be 2 pounds.

In a shop on a high mountain the forces on both would be less. They would both weigh less, but they would still be equal, as would be their masses. But note that if weight is measured as such, by means of a spring balance, then the quantity of sugar you would get in the mountain shop would be more than you would get at sea level with the machine indicating the same weight. In a spaceship a spring balance would indicate nothing at all, however much was hung on it.

Coherence

To deserve the name of system, all units should be *coherent*. That is to say, the primary unit of every derived quantity should be defined in terms of unit amount of each fundamental quantity involved. If one of the fundamental quantities is mass, then the coherent unit of force must be that required to accelerate *unit* mass at the rate of *unit* length per *unit* time per *unit* time. In the c.g.s. version of the metric system this is true of its unit of force—the dyne. And so it is in the m.k.s. version, whose unit of force is the newton. But what about our own f.p.s. (foot-pound-second) system? A mechanical engineer reckons pressure in pounds per square inch. In this use of the word "pound" he obviously doesn't mean mass, for that would be nonsense. Pressure is *force* per unit area. So in this context a pound is the force of gravity on a mass of a pound. Since the force of gravity depends on the position of the mass in relation to the body attracting it—the earth—and is not the same even at sea level everywhere, the pound force has no precise meaning unless a figure is given for the rate of gravitational acceleration. The agreed figure in feet/sec is 32.1740.

So two possibilities exist for a coherent f.p.s. system. The pound can be the unit of mass, in which case the unit of force is that which would be needed to accelerate a pound at the rate of 1 ft/sec. As force is proportional to acceleration, such a unit force is 1/32.174 of a pound weight (which as we have just seen is deemed to accelerate a pound mass at 32.174 sec²). This coherent unit is called a poundal, and no very abstruse calculation is needed to show that it is equal to just under half an ounce weight at the presumed standard sea level. Or the pound can be the unit of weight (in its true sense, which is force). In which case the coherent unit of mass is equal to 32.174 pounds mass, because the force of a pound applied to it would accelerate it at 1 ft/sec. Again, this unit has been given a name—the slug.

With our unrivalled British capacity for muddle, we not only legally define the pound as a unit of weight when mass is meant, but we reject both of the above legitimate systems in favour of a strange mixture of the two, in which "pound" sometimes means one thing and sometimes another 32.174 times larger or smaller. To call this a *system* is downright flattery.

For completeness of information, we note that *g*, the presumed acceleration due to gravity, is 980.665 cm/sec in the c.g.s. system and 9.80665 m/sec in the m.k.s. system, so the dyne is just over one milligramme weight and the newton is just over one tenth of a kilogramme weight and therefore equal to 10⁵ dynes.

The value of a coherent system of units is not just that it sounds better than an incoherent one; it has the great value that all the equations that state relationships between physical quantities can be used for computations without having to think about units or bring in constants to allow for them. For example, the equation for kinetic energy

E in terms of mass *m* and velocity *v* is

$$E = \frac{1}{2} mv^2 \dots \dots \dots (1)$$

This does not depend on units, so long as they are coherent. The $\frac{1}{2}$ is not a constant needed to express the result in a particular unit, but arises from the physics of the thing. So if *m* is in pounds and *v* in ft/sec, *E* is in the corresponding coherent unit of energy, the foot-poundal. But if you want it in foot-pounds (force) you have to divide the result by the constant *g*, 32.174; or (what is the same thing) modify the equation to

$$E = \frac{1}{2} mgv^2 \dots \dots \dots (2)$$

Obviously there is much less risk of error or confusion if each physical-law equation always appears in only one form. Equation (2) can rightly be objected to because *g* is being used as just a number—a unit-conversion constant—whereas it really has the dimensions of an acceleration and so makes the equation false dimensionally. If one were making a check—as one should—by seeing that the dimensions in terms of M, L and T (length, mass and time) were the same on both sides, one would find (2) wrong.

A criticism brought against the m.k.s. system (and SI) is that one doesn't (for example) want to measure the cross-sectional areas of pickup magnets in square metres. And if centimetres are used instead then the system ceases to be coherent. But this is not so if the prefix "centi" is regarded as part of the arithmetical amount to be filled into the relevant equations. For example, for "2 cm²" you would write "2 × 10⁻⁴m²."

All the same, I suppose it would have to be admitted that on the whole the sort of quantities we use are a little more easily expressed in centimetres and grammes than in metres and kilogrammes. That being so, the onus was on advocates of m.k.s. to show why c.g.s. should not continue to be used.

That would have been difficult to do in pre-electrical days. But not now. When units of electricity and magnetism were first defined, the c.g.s. system was universally used for scientific purposes, so naturally it was extended to include the new quantities. The system for electrical units was based on the law of attraction between opposite electric charges, and the system for magnetic units on the law of attraction between (non-existent) opposite magnetic poles. Because of the relationships between electricity and magnetism, both systems of units could be and were extended to include all electric and magnetic quantities, and so there were two alternative c.g.s. units for each.

Dimensions

Now we have already had something to say about the "dimensions" of physical quantities. For example, because of physical laws, force has the dimensions mass × acceleration, and acceleration in terms of the fundamental quantities is length/time². So we say the dimensions of force are ML/T². Anything that a force is equal to must have these dimensions, or something is wrong. The law of the force *F* between two electric charges *Q*₁ and *Q*₂ concentrated at points separated by distance *r* is

$$F = k \frac{Q_1 Q_2}{\epsilon r^2} \dots \dots \dots (3)$$

where *k* is a constant depending on the system of units and ϵ is the permittivity of the medium. So the electrostatic c.g.s. unit of charge is defined as that which spaced 1 cm from an equal and opposite charge in a vacuum is attracted with a force of 1 dyne, *k* and ϵ both being regarded as 1. The dimensions of charge are therefore the square root of (force × length²), or L^{1/2} M^{1/2} T⁻¹. The electromagnetic c.g.s. unit of charge, on the other hand, turns out to have the dimensions L^{3/2} M^{1/2}. But this is nonsensical! The ratio

of two quantities of the same kind *must* be a pure number, with no dimensions. But the ratio of any amount of electric charge in e.s.u. to the same amount in e.m.u. is

$$\frac{L^{\frac{1}{2}}M^{\frac{1}{2}}T^{-1}}{L^{\frac{1}{2}}M^{\frac{1}{2}}T^{-1}} = \frac{L}{L}$$

which of course is a velocity.

Do the same for any electric or magnetic quantity and you always get a velocity, or the square of a velocity. And always the same velocity— 2.99792×10^{10} cm/sec, which of course is the velocity of electromagnetic waves through space.

The fallacy responsible for the absurdity mentioned above was the assumption that ϵ was a pure number (1); and the same for μ in the magnetic case. Now nobody knows what the dimensions of ϵ and are μ , but we do know that $1/\sqrt{\epsilon\mu}$ has the dimensions of velocity. Nor can the magnitudes of ϵ and μ both be made 1 (while retaining the second as the unit of time) other than by making our unit of length equal to 2.99792×10^{10} cm, which would hardly be a popular move.

What it all boils down to is that electrical and magnetic quantities can't be expressed in terms of the three fundamental (or any other) mechanical quantities, but need at least one electromagnetic quantity. Any one would do, but for convenience it has been decided internationally that it should be electric current.

Besides being fundamentally unsound, as we have seen, both of the c.g.s. systems were highly inconvenient in that their units were quite different from those in practical use, such as volts, amperes and ohms. Most of them were much too small or too large; for example, the e.m.u. unit of e.m.f. was equal to one hundredth of a microvolt, and unit capacitance was one thousand million farads. By making the four fundamental units the metre, kilogramme, second and ampere, all the coherent units of electricity and magnetism are the same as those in general use. And, incidentally, the units of force and of energy and work are of more convenient size than the dyne and erg. In particular, the unit of energy and work is the

same for mechanical and electrical work—the watt-second, or joule. The only inconvenience is that the values of ϵ and μ in space are not 1.

On the whole, however, this m.k.s.A. system is both sound and convenient, and the sooner all others are consigned to past history the better. The c.g.s. systems are rapidly moving in that direction, as well they might!

We have admittedly been taking rather a self-centred electrical view of things—not without some justification in view of the electrical constitution of all things. But even the strictly mechanical engineer can hardly fail to benefit from at least one by-product of the adoption of what is basically the m.k.s.A. system—the replacement of 15 different units of heat, all called the *calorie*, by one already well-established—the joule. Heat is now defined in electrical terms.

Temperature *could* be defined in terms of the same four fundamental quantities, but for convenience the degree Kelvin has been made a fifth quantity in the SI. To bring units of light into it, the unit of luminous intensity, the candela, is a sixth. So what we now have is an m.k.s.A.°K.cd system, SI for short. The SI agreement includes several changes besides the abolition of separate heat units. The standard metre is no longer a metal bar but 1,650,763.73 wavelengths *in vacuo* of a certain radiation from the gas krypton. The second is also being re-defined in atomic terms, as a number or cycles of a certain transition of caesium. The only one of the original three standards to remain is the kilogramme, kept at Sèvres in France. Greater precision could be obtained by specifying it as the number of atoms of a given element, but counting them with available facilities would be rather laborious. Before that becomes practicable, no doubt the ampere will be re-defined as a number of electrons per second, instead of the force between two conductors carrying it.

May I suggest that, without waiting for these or any other developments, all readers who have not already done so accustom themselves to the use of SI?

H. F. PREDICTIONS—JANUARY

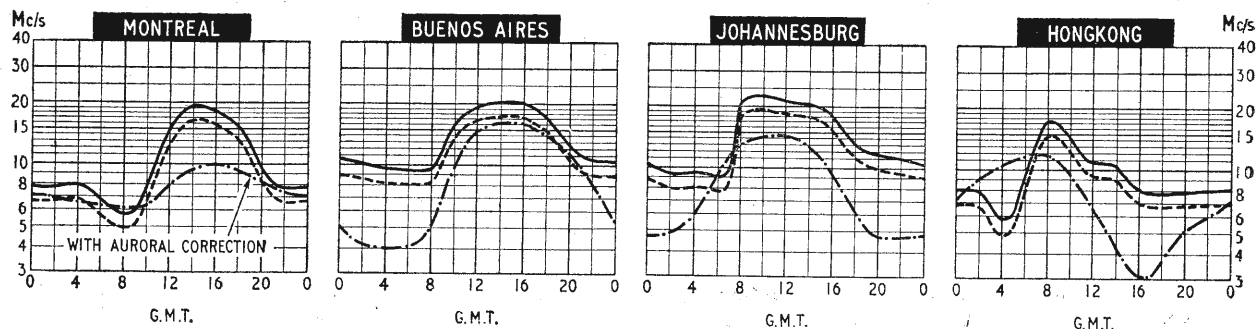

The prediction curves show the median standard MUF, optimum traffic frequency and the lowest usable frequency (LUF) for reception in this country. Unlike the standard MUF, the LUF is closely dependent upon such factors as transmitter power, aeriels, and the type of modulation. The LUF curves shown are those drawn by Cable & Wireless Ltd. for commercial telegraphy and assume the use of transmitter power of several kilowatts and rhombic type aeriels.

The Zurich sunspot number predicted for November was 6

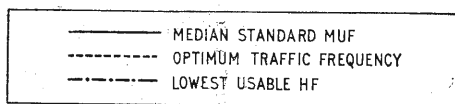

but it was actually 6.9. The predicted numbers for December to May inclusive, *i.e.* 6, 6, 7, 7, 8, 9, respectively, suggest that the sunspot minimum has past. A steady rise would now be expected over the next few years.

WORLD OF WIRELESS

U.K. Radio Shows

SINCE the closing of the last National Radio Show at Earls Court, which was attended by over 200,000 fewer than the previous exhibition two years earlier, there have been frequent discussions on the future of the London show. Should it be biennial? Should it be international? Should it become a purely trade show? etc. Before B.R.E.M.A., the sponsors, had made up their minds the Thomson Organization announced that they were to hold an international radio show in Newcastle to coincide with the annual Tyneside Summer Exhibition in the first week in August. (The date has subsequently been changed to August 17th-21st.)

Within a few days of this announcement Industrial & Trade Fairs announced that they had taken over the promotion and organization of annual radio and television exhibitions at Earls Court. These would be international and would replace those formerly run by B.R.E.M.A. who had options on dates for several years. It is understood that other trade associations will be invited to participate in the show which it is intended to broaden to cover other forms of home entertainment. The first of this new series of shows will run from August 25th-September 4th.

The opening of the doors of the London show to overseas manufacturers may mean that the organizers of the German show—to be in Stuttgart this year—will reciprocate. In the past they have offered to do this if we in the U.K. did likewise.

Will the introduction of international shows mean the disappearance of the plethora of trade shows staged by individual manufacturers and importers coincident with the London Show?

Royal Society

AS a result, in part, of a recommendation by an *ad hoc* committee set up last year "to consider what action the Royal Society might take . . . to heighten the esteem of the technologist as a scientific contributor to the national welfare" the number of annual elections of Fellows is to be increased from 25 to 32. The intention is that a substantial number of the new places should be given to applied scientists on both the physical and biological sides.

In the report of the committee on scientific research in schools issued by the Society details are given of some 100 research projects being undertaken by science teachers. These include an investigation of radio emission from sunspots (Bradford Grammar Sch.); radio communication on 430 Mc/s by reflection from the moon (Canford School, Wimborne); the measurement of ionospheric drifts (Tregaron County Secondary Sch.); construction of a 200 Mc/s radio telescope (Gordonstoun Sch.) and radio astronomy (Westminster Sch.).

Quality of Instruments

A CONFERENCE on the performance and quality of instruments, organized by the Scientific Instrument Manufacturers' Association recently, discussed how far criticisms of British instruments were justified, how to ensure that they are capable of meeting the users' requirements, and how to sell more overseas.

Points that came to light included the need for the pooling of information from the field engineers and servicing establishments and feeding it back to the design teams to help improve the reliability of later designs; more fundamental analysis of unnecessary cost (*i.e.* cost that provides neither better quality, nor extended use, nor improved life); the implications of changing to the metric system; cheap and quick evaluation of instruments; and extending the existing calibration facilities now available to the industry.

Dr. J. V. Dunworth, acting director of the National Physical Laboratory, discussed the scheme for establishing calibration centres under the auspices of the N.P.L.

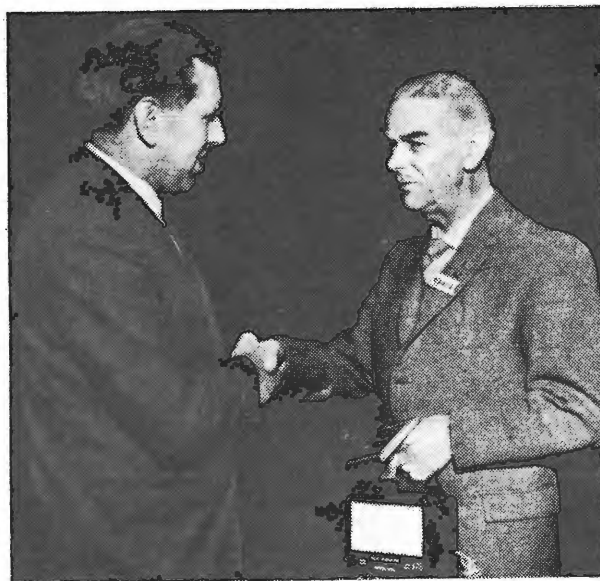

Mullard Award of the Radio Society of Great Britain being received by James Illingworth (right), a blind amateur transmitter (G3EPL) of St. Bees, Cumberland. The award of books or apparatus to the value of £25 is donated by Mullard and is given to an R.S.G.B. member who has, through the medium of amateur radio, rendered outstanding personal service to the community by his own endeavours or by his example of fortitude and courage.

I.E.R.E.—As already announced, the new president of the Institution of Electronic and Radio Engineers is Colonel G. W. Raby. The Institution's new vice-presidents are R. H. Garner, principal of Coatbridge Technical College; Major General B. D. Kapur, until recently controller of defence research and development in India's Ministry of Defence; H. F. Schwarz, managing director of Decca Navigator; and Professor Emrys Williams, of University College of South Wales and Monmouthshire. New members of the Council are: R. J. Cox (Atomic Energy Establishment, Winfrith); T. A. Cross (Redifon); Rear-Admiral C. R. Darlington (Ministry of Defence); Professor W. A. Gambling (University of Southampton); N. L. Garlick (Brighton College of Technology) and M. James (Industrial Electronics Division in the U.K. of International G.E. Company).

Among the nine premiums awarded at the annual meeting of the I.E.R.E. was a new one—the **J. Langham Thompson Premium**—endowed by Mr. Thompson, the retiring president, for "the outstanding paper in the field of control engineering." The first recipients of the 30gn award were G. B. Cole and S. L. H. Clarke, both of Elliott Process Automation Ltd., for their joint paper "The development of ARCH—a hybrid analogue-digital system for computers for industrial control." The Institution has announced a further award which has been endowed by Radio Rentals Ltd. to commemorate their founder P. Perring-Thoms. It will be presented annually for the most outstanding contribution on improved methods of television reception.

B.K.S.T.S.—Since the merger a few months ago of the British Sound Recording Association with the British Kinematograph Society there have been several attempts to find a new "all embracing" title. It has now been decided to register the name British Kinematograph Sound and Television Society.

R.T.E.B. and S.E.R.T.—Since the formation of the Radio Trades Examination Board in 1942 secretarial assistance has been provided by the Institution of Electronic and Radio Engineers at its offices at 9 Bedford Square, London, W.C.1. With the expansion of the Board's activities and the establishment of the Society Electronic and Radio Technicians, these two organizations have moved to 33 Bedford Street, London, W.C.2. The telephone numbers are COVent Garden 0926 (R.T.E.B.) and 1152 (S.E.R.T.). As announced elsewhere in this issue, A. J. Kenward is now secretary of both organizations.

I.E.R.E. Membership.—The Report of the Institution of Electronic and Radio Engineers for the year ended last March, which was presented at the a.g.m. on December 9th, records a net gain in membership of 832 during the year bringing the total to 9,531. Just under a third of the total (3,100) are graduates and another 2,800 associate members.

A total of some 300 exhibitors have already booked space for the **Radio & Electronic Component Show** to be held at Olympia, London, from May 18th to 21st. This is almost a 20% increase on the 1963 figure. Sponsored by the Radio & Electronic Component Manufacturers' Federation, it is organized by Industrial Exhibitions Ltd.

I.E.A. 1966.—The dates of the next International Instruments, Electronics and Automation Exhibition—May 23rd-28th, 1966—have been announced by the organizers, Industrial Exhibitions Ltd., 9 Argyll Street, London, W.1. The biennial exhibition is sponsored by the British Electrical and Allied Manfrs' Assoc., Radio and Electronic Component Manfrs' Fed., British Industrial Measuring and Control Apparatus Manfrs' Assoc., Electrical Engineering Assoc. and Scientific Instrument Manfrs' Assoc.

Television for Barbados.—The Caribbean Broadcasting Corporation's first television station was brought into service on December 15th. The 625-line station is located in Bridgetown, Barbados. The channel width is 6 Mc/s. Studio equipment, including 4½-in image-orthicon cameras and telecine units, was supplied by Pye T.V.T.

Pakistan's first television station, built in the West Pakistan capital of Lahore, was inaugurated by the president on November 26th. A second station is opening soon in Dacca, the eastern capital. Both transmitters, which operate on the 625-line 7 Mc/s standard, were supplied by Nippon Electric Company of Japan.

A joint I.E.R.E.-I.E.E. symposium on **microwave applications of semiconductors** is to be held at University College, London, from June 30th to July 2nd.

Microwave Behaviour.—An international conference on the microwave behaviour of ferrimagnetics and plasmas is being organized for next September by the I.E.E. in collaboration with the I.E.R.E., the U.K. Section of the I.E.E.E. and the Inst. Phys. & Phys. Soc. It will be held at the I.E.E. headquarters, Savoy Place, London, W.C.2.

Electronics Design.—A two-day conference on the design of electronic equipment, covering the commercial, manufacturing, aesthetic and ergonomic aspects as well as those concerned with technical performance, is being organized by the Electronics Division of the I.E.E. for 8th and 9th February at Savoy Place, London, W.C.2. Registration forms are obtainable from the Institution at the above address.

Correction.—In line 23, r.h. column, page 614 of R. B. C. Copey's article in the December 1964 issue on a transistor f.s.k. oscillator, the second term of the expression for the input to Tr3 should be the same as in eqn. (1) with index $j\Omega$, not $j2\Omega$.



The commemoration stamp issued on December 15th by the United States Post Office to mark the 50th anniversary of the founding of the American Radio Relay League. A specially designed envelope bearing a reproduction of the first cover of the League's journal QST was used for first day cancellations.

Engineering scholarships combining undergraduate and post-graduate education are announced by the English Electric group of companies. The scholarships will include awards of £550 a year for three years to undergraduates following a course leading to an honours degree in mechanical engineering, electrical engineering, electronics, production engineering or some other related applied science. For those who have completed a year's practical training with the company and have a 1st- or 2nd-class honours degree, awards to the value of £825 a year will be available.

A course of twelve weekly lectures on **microwave applications of semiconductors** begins at the Borough Polytechnic, Borough Road, London, S.E.1, on January 12th (fee 50s). Incidentally, proposals for the erection of a major extension to the college, providing an extra 140,000 sq ft of accommodation, have been approved. This would more than double the existing space.

Three courses, each of two weeks' duration, to "provide a deeper insight into the circuit techniques, applications and maintenance procedures" of **Tektronix instruments** and their sampling and digital systems, are being arranged by Tektronix Ltd. at their Guernsey, Channel Islands, training department. Each course is repeated at intervals of approximately a month. They start in January. Details of the courses, which are free but travel and accommodation have to be paid for, are obtainable from J. Thompson, Tektronix U.K. Ltd., Beaverton House, Station Approach, Harpenden, Herts.

An evening course of 12 lectures on **statistical signal theory** begins at the Brunel College, London, W.3, on January 12th. It is intended for engineers and scientists who already have a basic knowledge of information theory. (Fee 2 gn.)

A course of six Tuesday evening lectures in **radar technology**, commencing February 2nd, are to be held at the Norwood Technical College, Knight's Hill, London, S.E.27. (Fee 15s.)

Two courses, each of 12 weekly lectures, start at the **Northern Polytechnic**, London, N.7, on January 14th. In the afternoon there will be a course on printed circuit techniques (fee £2) and in the evening one on basic microwave techniques (fee £1). A course of 14 lectures on the principles of modern network theory, with an introduction to synthesis, starts on January 15th (fee 30s).

A course of 11 weekly evening lectures providing an introduction to the theory and application of **lasers, masers and parametric amplifiers**, begins at the Twickenham College of Technology, Egerton Road, Twickenham, Middx., on January 15th. (Fee 55s.)

At the presentation of prizes to apprentices at the Marconi Company's works at Chelmsford on December 4th the education and training officer announced that 738 apprentices are at present in training. Of this number 380 are craftsmen, 157 technicians, 143 students and 58 graduates. Apprentices' successes in the various exams for degrees, diplomas and certificates reached the high level of 78% during the past year.

Automatic Control.—London is to be the venue of the third congress of the International Federation of Automatic Control which is to be held from June 20th-25th, 1966. Organization is in the hands of the U.K. Automation Council, c/o I.E.E., Savoy Place, London, W.C.2.

The Society of Environmental Engineers is planning to hold its second symposium and exhibition in London in April 1966.

A twenty-minute colour film entitled "Solder Glass Technique" is now available for hire from the Central Film Library, Industrial Section, Government Building, Bromyard Avenue, Acton, London, W.3. Professor King, of the M.I.T. of America, demonstrates a simple method of producing inexpensive vacuum tube devices for experimental use from ordinary soft glass tubing and solder glass.

Three new pamphlets in the series "Educational Electronic Experiments" are available from the Mullard Educational Service, Mullard House, Torrington Place, London, W.C.1. The first of these—number eight in the series—deals with the construction of a low-voltage electrometer which is particularly suitable for all pH measurements. Number nine describes the construction of a decade scaler which has a maximum count rate of 400 c/s and will accept and count most standard waveforms. A method of making Hall effect measurements is described in pamphlet ten and samples of semiconductor wafers for this purpose are available from the Educational Service. No charge is made to schools and other educational establishments for these pamphlets. Although not in the Electronic Experiments series, a list of elements giving atomic number and weight, electron shell dispositions, periodic group and neutron complement is available from the Educational Service.

ESTEC—the European Space Technology Centre—at present operating from buildings belonging to the Technical University of Delft, is to set up its own establishment a few kilometres south of Noordwijk. This decision was announced by the Council of ESTEC at its meeting on the 22nd October attended by delegates from all nine member countries:—Belgium, Denmark, Federal Republic of Germany, France, Netherlands, Spain, Sweden, Switzerland and U.K.

PERSONALITIES

Sir Robert Renwick, Bt., K.B.E., who was appointed a baron in the Honours List on the dissolution of Parliament, is chairman of Associated Electrical Industries, Associated Television, British Relay and the British Space Development Corporation. During the last war Sir Robert was closely associated with the development of radar by virtue of the positions he held in the Supply and Air Ministries. For the past ten years he has been president of the Radar & Electronics Association.

Walter Bruch, who developed the PAL television system, has been appointed an honorary doctor of engineering by the Hanover Technical University "for his excellent scientific achievements in the domain of colour television." Dr.-Ing. Bruch, who is 56, joined the television and physical research department of Telefunken in 1935. After the war he ran his own laboratory in Berlin for four years but returned to Telefunken in 1950. He is a member of the *ad hoc* colour television group of the European Broadcasting Union and of Study Group XI (television) of the C.C.I.R.

E. L. C. White, Ph.D., M.A., M.I.E.E., for the past three years in charge of military projects research for EMI Electronics, has been appointed chief scientist. Dr. White joined EMI Research Laboratories in 1933 and was a member of the team led by the late Sir Isaac Shoenberg which developed the 405-line television system. During

the war he was engaged on radar development and subsequently on the design of television cameras. In his new position he will be responsible for the



Dr. E. L. C. White

technical executive duties hitherto carried out by the technical director, **Arthur H. Cooper, C.B.E., B.Sc.**, who has left the country to become a director of the recently formed EMI Electronics (Australia) Pty., Ltd. Mr. Cooper, who is 60 and is a graduate of King's College, London, was in the research laboratories of the G.E.C. and then the B.B.C. before joining the Gramophone Company (now part of EMI) in 1929. He was appointed head of advanced development of EMI in 1932 and was in charge of the work on proximity fuses. He has been technical director of EMI Electronics since 1956.

Captain J. W. G. James, O.B.E., F.R.Ae.S., M.Inst.P., who has been flight operations and communications director of British European Airways since 1952, has been appointed a full-time member of the board of B.E.A. for a period of five years from December 1st.

J. G. Thompson, Assoc.I.E.E., director of telecommunications, Singapore, for the past two years has resigned to take up an appointment with the International Civil Aviation Organization and will be seconded to the government of Libya as senior radio engineer. Mr. Thompson, who is 42, served in the R.A.F. Signals Branch during the war and in 1946 was seconded to the Forces Broadcasting Service. He left the R.A.F. in 1950 but remained with F.B.S. in a civilian capacity to become senior technical officer, Middle East. A year later he joined the Government Telecommunications Department, Singapore, and after serving as engineer-in-charge of radio transmitting and receiving stations was controller of the Radio Branch from 1960 until his appointment as director of telecommunications in 1962.

R. W. Beattie, manager of the capacitor division of the Telephone Manufacturing Company, Ltd., has been appointed an executive director. As divisional manager, Mr. Beattie is responsible for all aspects of production, sales and engineering of T.M.C.'s capacitor division.

Colonel E. N. Elford, O.B.E., T.D., A.M.I.E.E., has retired from Marconi's after 27 years' service. He was manager of the company's radar division from 1948 until 1960 when he was appointed consultant to the managing director, particularly in the defence field. Col. Elford originally joined Marconi's as an unpaid trainee in 1915 but left to join the Regular Army in 1917. He was commissioned in the Royal Artillery but invalided out and resumed his career in the radio industry. He rejoined the Marconi Company in 1937 but as a Territorial Army officer was recalled at the outbreak of war in 1939. He returned to Chelmsford in 1945 and was instrumental in the formation of what is now the radar division.

H. Stephen Marmorek, M.A., who graduated at Cambridge University and following service in the Second World War as a captain in R.E.M.E. went to North America, has become president of Sprague-TCC (Canada) Ltd. This is the joint Canadian subsidiary of the Telegraph Condenser Company, of London, and the Sprague Electric Company, of North Adams, Mass. Mr. Marmorek was for some years works manager of Radio Engineering & Products Ltd., of Montreal.

The recently appointed director of technical costings in the Ministry of Aviation is **H. E. Drew, M.I.E.R.E.**, and not E. C. Drew as stated in error last month. Mr. Drew joined Sir Robert Watson-Watt's staff at the Bawdsey Research Station in 1938 after 14 years in the R.A.F. In 1946 he became a member of the headquarters staff of the Ministry of Supply's Directorate of Radio Production. He was director of electronics production (air) from 1959 until his new appointment on October 1.

G. Caldwell, B.Sc., A.M.I.E.E., is to be the new head of the Department of Electrical Engineering in the Borough Polytechnic, London, S.E.1, from January 1st in succession to **V. P. Mendoza, M.Sc.Tech., M.I.E.E.**, who was recently appointed vice-principal. Mr. Caldwell, who is 44 and is a graduate of the University of Manchester, has been head of the Department of Electrical Engineering at the Oxford College of Technology. He has also been a member of the academic staff of the Loughborough College of Technology and was for some time principal of the Apprentice Training School of the U.K. Atomic Energy Authority at Harwell.

R. A. King, M.A., A.M.I.E.E., lecturer in the electrical engineering department of Imperial College, London, has been seconded for three years to the Indian Institute of Technology, Delhi, as professor of electrical engineering (control engineering).

Colonel E. Holland, B.Sc.(Eng.), A.M.I.Mech.E., A.M.I.E.E., R.E.M.E., assistant director electrical and mechanical engineering in the Ministry of Defence since April, 1963, has been appointed director of electrical inspection in the Ministry of Aviation in succession to E. D. Whitehead who is now director of electronics production (radar). Col. Holland has been granted the rank of Brigadier.

G. D. Clifford, C.M.G., secretary of the Institute of Electronic and Radio Engineers which he joined in 1937, is retiring from the post of secretary of the Radio Traders Examination Board he has held since the formation of the Board of which the I.E.R.E. is one of the four sponsoring bodies. **A. J. Kenward, B.Sc., A.M.I.E.R.E.**, who is a graduate of London University and has been education officer of the I.E.R.E. since 1948, is being released to become secretary of the R.T.E.B. and of the recently formed Society of Electronic and Radio Technicians.

G. N. Patchett, B.Sc.(Eng.), Ph.D., M.I.E.E., M.I.E.R.E., who has been head of the Electrical Engineering Department of Bradford Institute of Technology for the past 12 years, has been appointed a professor of electrical engineering in the proposed University of Bradford. Dr. Patchett has been on the staff of the College since 1940 when he joined to teach Servicemen radio. He received his own academic training at the College where he graduated B.Sc. (electrical engineering). He received his Ph.D. from London University in 1946.

W. F. Lovering, M.Sc., M.I.E.E., head of the Electrical Engineering Department of Battersea College of Advanced Technology, London, has been appointed to the chair of electrical and control engineering. This is one of several appointments to personal chairs in anticipation of the granting of university status to the college. Mr. Lovering, who is 51 and a graduate of Birmingham University, was in industry (Ferranti, G.E.C. and Stratton) for some years before joining the staff of Nottingham University as a lecturer. He subsequently served on the staff of the University of New South Wales, Australia, and of Imperial College, London.

William A. Gambling, Ph.D., B.Sc. (Eng.), A.M.I.E.E., senior lecturer in the Department of Electronics at Southampton University until his appointment a year ago as reader in electronics, has now been appointed to the University's second chair of electronics. The incumbent of the other chair is Dr. Geoffrey D. Sims who succeeded to the professorship on the retirement of Dr. E. E. Zepler a year ago.

The Copley Medal of the Royal Society has been awarded to **Professor S. Chapman, F.R.S.**, advisory scientific director of the Geophysical Institute, University of Alaska, for his theoretical contributions to terrestrial and interplanetary magnetism, the study of the ionosphere and of the aurora borealis.

OUR AUTHORS

J. L. Storr-Best, B.Sc.(Eng.), A.M.I.E.E., author of the article on miniature selenium rectifiers for television e.h.t. in this issue, obtained a First Class Honours degree of London University at Brighton Technical College. From 1940 until 1959 he worked in the Radio Division of Standard Telephones & Cables at New Southgate. In 1959 he became head of the laboratory designing digital transistor circuits for electronic telegraph switching equipment. Since February, 1963, he has been chief applications engineer for the Rectifier Division of S.T.C. at Harlow.

M. D. A. B. Rackowe, B.A., contributor of the article on page 24, graduated in the mechanical sciences tripos at Pembroke College, Cambridge. He then spent a year with English Electric Aviation working on guided weapon control circuitry after which he joined Everett Edgcombe & Co. where he was concerned mainly with the development of a.c. and d.c. amplifiers. From January, 1963, until last June he was with AMF British Research Laboratory, Reading, and is now with Coutant Electronics, of Reading. He is 28.

OBITUARY

Charles Samuel Franklin, C.B.E., M.I.E.E., who died on December 10th at the age of 85, will always be honoured for the prominent part he played in the creation of beam wireless, although at the time of his retirement from the Marconi company in 1939 he modestly pointed out that "beamed" short-wave transmission is as old as wireless itself. After extensive experiments, both in this country and abroad, an aerial with a large reflector was erected at Poldhu, Cornwall, and its transmissions on 100 metres and below were received on Marconi's yacht *Elettra* in various parts of the world. Having proved the value of beamed short-wave communication a contract was obtained from the Post Office in 1925 for a number of stations. Franklin was one of the original band of engineers who joined the Marconi company on its formation in 1899 and is perhaps best known as the originator of the high-stability oscillator bearing his name. In 1949 he received the Faraday Medal of the I.E.E. for "his distinguished work in radio engineering, and more particularly for his development of the beam aerial and other devices that made long-range h.f. communication a practical possibility."

CONFERENCES AND EXHIBITIONS

Latest information on events during 1965 both in the U.K. and abroad is given below.
Further details are obtainable from the addresses in parentheses.

LONDON

- Feb. 8-9 Savoy Place
Conference on Electronics Design
(I.E.E., Savoy Place, W.C.2)
- Feb. 26 Savoy Place
Cryogenics in Relation to Vacuum
(Inst. Phys. & Phys. Soc., 47 Belgrave Sq., S.W.1)
- Mar. 17-18 Kings Head, Harrow
Public Address Exhibition
(A.P.A.E., 394 Northolt Rd., South Harrow, Middx.)
- Mar. 29-Apr. 2 Earls Court
LABEX—Laboratory Apparatus & Materials Exhibition
(Scientific Instrument Manfrs. Assoc., 20 Peel St., W.8)
- Apr. 21-30 Olympia & Earls Court
International Engineering Exhibition
(F. W. Bridges & Sons, 1-19 New Oxford St., W.C.1)
- Apr. 22-25 Hotel Russell
International Audio Festival & Fair
(C. Rex-Hassan, 42 Manchester St., W.1)
- May 17-21 Savoy Place
Components & Materials in Electronics Engineering
(I.E.E., Savoy Place, W.C.2)
- May 18-21 Olympia
Component Show
(R.E.C.M.F., 21 Tothill St., S.W.1)
- May 20-21 R.Ac.S., Hamilton Place, W.1
Electrical Conduction at Low Temperatures
(Inst. Phys. & Phys. Soc., 47 Belgrave Sq., S.W.1)
- June 16-26 Olympia
Interplas Plastics Exhibition
(British Plastics, Dorset House, Stamford St., S.E.1)
- Aug. 25-Sept. 4 Earls Court
Radio Show
(Industrial & Trade Fairs, 1-19 New Oxford St., W.C.1)
- Sept. 13-17 Savoy Place
Microwave Behaviour of Ferrimagnetics & Plasmas
(I.E.E., Savoy Place, W.C.2)
- Sept. 20-24 Savoy Place
Thermionic Electrical Power Generation
(I.E.E., Savoy Place, W.C.2)
- Oct. 27-30 Seymour Hall
R.S.G.B. Radio Communications Show
(P. A. Thorogood, 35 Gibbs Green, Edgware, Middx.)

BIRMINGHAM

- Apr. 5-7 The University
Conference on Elementary Particles
(Inst. Phys. & Phys. Soc., 47 Belgrave Sq., S.W.1)

BRIGHTON

- Sept. 28-Oct. 1 Hotel Metropole
European Medical Electronics Symposium & Show
(Symposium Secretary, 4 Mill Street, W.1)

BRISTOL

- Jan. 5-8 The University
Conference on Solid State Physics
(Inst. Phys. & Phys. Soc., 47 Belgrave Sq., S.W.1)
- Apr. 7-9 The University
Stress Analysis Conference
(Inst. Phys. & Phys. Soc., 47 Belgrave Sq., S.W.1)

CAMBRIDGE

- Mar. 31-Apr. 2 The University
Non-Conventional Electron Microscopy
(Inst. Phys. & Phys. Soc., 47 Belgrave Sq., S.W.1)
- Sept. 1-7
British Association Meeting
(British Assoc., 3 Sanctuary Bldgs., Great Smith St., S.W.1)

LIVERPOOL

- Sept. 15-17 The University
Nuclear and Particle Physics
(Inst. Phys. & Phys. Soc., 47 Belgrave Sq., S.W.1)

MANCHESTER

- Apr. 5-8 Col. of Science & Tech.
Physics Exhibition
(Inst. Phys. & Phys. Soc., 47 Belgrave Sq., S.W.1)
- Sept. 7-9 The University
Internal Friction in Solids
(Inst. Phys. & Phys. Soc., 47 Belgrave Sq., S.W.1)

NEWCASTLE

- Aug. 17-21 Town Moor
International Radio Show
(Thomson Organisation, 200 Gray's Inn Rd., W.C.1)

NOTTINGHAM

- Apr. 6-9 The University
Automatic Control Convention
(I. Mech. E., 1 Birdcage Walk, S.W.1)

SCARBOROUGH

- May 23-27 Royal Hotel
R.T.R.A. Annual Conference
(Radio & Television Retailers' Assoc., 19 Conway St., W.1)

OVERSEAS

- Jan. 12-14 Miami Beach
Reliability and Quality Control
(R. Brewer, Mullard Southampton Works, Southampton, Hants.)
- Feb. 3-5 Los Angeles
Military Electronics Convention
(Dr. R. Ashby, North American Aviation, 3370 Miraloma Ave., Anaheim, Cal.)
- Feb. 17-19 Philadelphia
Solid State Circuits Conference
(Lewis Winner, 152 W. 42nd St., New York, N.Y.)
- Feb. 28-Mar. 9 Leipzig
Leipzig Fair
(Leipziger Messeamf, Post Box 329, Leipzig)
- Mar. 10-12 Washington
Particle Accelerator Conference
(I.E.E.E., Box A, Lenox Hill Station, New York 21)
- Mar. 11-16 Paris
Festival of Sound
(F.M.I.E., 16 rue de Presles, Paris 15e)
- Mar. 22-26 Canberra
Australia and the Electronics World
(Institution of Radio and Electronics Engineers Australia, Box 3120, G.P.O., Sydney)
- Mar. 22-29 New York
International Convention
(I.E.E.E., Box A, Lenox Hill Station, New York 21)
- Mar. 23-26 Los Angeles
Audio Convention
(Audio Engineering Soc., P.O. Box 383 Maddison Sq. Station, New York.)
- Apr. 5-10 Paris
Symposium on Techniques of Memories
(Société Française d'Electroniciens et des Radioelectriciens, 10 avenue Pierre-Larousse, Malakoff)
- Apr. 8-13 Paris
Electronic Components Exhibition
(F.N.I.E., 16 rue de Presles, Paris 15e)
- Apr. 8-13 Paris
Audio Equipment Exhibition
(F.N.I.E., 16 rue de Presles, Paris 15e)
- Apr. 12-17 Los Angeles
Technical Conference
(S.M.P.T.E., 9 East 41st St., New York 17, N.Y.)
- Apr. 13-15 Houston
Telemetering Conference
(R. W. Towle, Advanced Technology Labs., 369 Whisman Rd., Mountain View, Cal.)

- Apr. 14-15
Electronics and Instrumentation Conference
(J. R. Ebbeler, Avco Corp., 2630 Glendale-Milford Rd., Cincinnati) Cincinnati
- Apr. 20-22
Symposium on System Theory
(Polytechnic Institute of Brooklyn, 333 Jay St., Brooklyn 1, N.Y.) New York
- Apr. 20-22
Frequency Control Symposium
(M. F. Timm, U.S. Army Electronics Labs., Fort Monmouth) Atlantic City
- Apr. 21-23
Optimization Techniques
(I.E.E.E., Box A, Lenox Hill Station, New York 21, N.Y.) Pittsburgh
- Apr. 21-23
Nonlinear Magnetics
(Dr. E. W. Pugh, IBM Building 703-2, Poughkeepsie, N.Y.) Washington
- Apr. 24-May 2
Hanover Fair
(Schenkers Ltd., 13 Finsbury Sq., London, E.C.2) Hanover
- May 5-7
Microwave Theory & Techniques
(J. E. Pippin, Sperry Microwave Electronics Corp., Box 1828, Clearway, Fla.) Clearway, Fla.
- May 6-8
Human Factors in Electronics
(I.E.E.E., Box A, Lenox Hill Station, New York 21, N.Y.) Boston
- May 10-12
Aerospace Electronics Conference
(NAECON, 1414 E. 3rd St., Dayton 2, Ohio) Dayton
- May 19-25
Electronic Exhibition
(Elvabe, Molenaaloe 63A, Wilp, Gld., Netherlands) Amsterdam
- May 24-28
Television Symposium
(R. Jaussi, Postfach 97, Montreux, Switzerland) Montreux
- May 24-29
Information Processing Conference
(British Computer Soc., Finsbury Pavement, London, E.C.2) New York
- May 25-27
A.F.C.E.A. Annual Convention
(Armed Forces Communications & Electronics Assoc., 1725 Eye St., N.W., Washington, D.C.) Washington
- June 7-9
Communication Convention
(W. F. Ulant, N.B.S., Boulder, Colo.) Boulder
- June 20-24
Aerospace Conference
(T. B. Owen, 635 20th St., Santa Monica, Cal.) Houston
- June 22-25
Joint Automatic Control Conference
(Prof. J. W. Moore, University of Virginia, Charlottesville) Troy, N.Y.
- June-27-July 3
Navigation Congress
(British National Navigation Committee, c/o I.C.E., Gt. George St., London, S.W.1) Stockholm
- June 28-30
Electromagnetic Compatibility
(I.E.E.E., Box A, Lenox Hill Station, New York 21, N.Y.) New York
- June 28-July 2
Vacuum Congress
(Dr. H. Adam, 5 Köln-Bayental, West Germany, Postfach 195) Stuttgart
- Aug. 24-27
Western Electronics Show and Conference
(WESCON, 3600 Wilshire Blvd., Los Angeles, Cal.) San Francisco
- Aug. 25-Sept. 5
German Radio & TV Show
(Stuttgarter Ausstellungen—GmbH, Stuttgart, Postfach 990) Stuttgart
- Aug. 29-Sept. 3
Medical Electronics Conference
(Prof. K. Suhara, Tokyo University of Education, 26 Otsukakubomachi, Bunkyo-ku, Tokyo) Tokyo
- Aug. 30-Sept. 1
Antennas and Propagation
(Dr. R. J. Adams, Naval Research Lab., Washington D.C.) Washington
- Sept. 7-11
INEL—Industrial Electronics Exhibition
(Swiss Industries Fair, Postfach, Basle 21) Basle
- Sept. 7-14
International Congress on Acoustics
(5e Congrès International d'Acoustique, 35 rue Saint-Gilles, Liège, Belgium) Liège
- Sept. 14-Nov. 12
I.T.U. Plenipotentiary Conference
(International Telecom. Union, Place des Nations, Geneva) Montreux
- Sept. 17-Oct. 3
British Exhibition
(British Overseas Fairs, 21 Tothill St., London, S.W.1) Tokyo
- Sept. 22-24
Military Electronics Convention
(I.E.E.E., Box A, Lenox Hill Station, New York 21, N.Y.) Washington
- Sept. 27-Oct. 2
Technical Conference
(S.M.P.T.E., 9 East 41st St., New York 17, N.Y.) New York
- Oct. 4-6
Canadian Electronics Conference
(I.E.E.E., 1819 Yonge St., Toronto 7, Ontario) Toronto
- Oct. 7-12
Communication Congress
(I.C.C. Secretariat, c/o Civico Instituto Colombiana, Palazzo Tursi, Genoa) Genova
- Oct. 13-19
Interkama—Measuring Instruments & Automation
(J. Buck Ltd., 47 Brewer St., London, W.1.) Düsseldorf
- Oct. 25-27
National Electronics Conference
(N.E.C., 228 La Salle St., Chicago, Ill.) Chicago

Books Received

Transistor-Praktikum, by Marcus Tuner. A light-hearted, but nevertheless sound introduction (in German) to the apparently nonsensical peculiarities of transistor techniques. Cartoons alternate with specific circuit details and the reader is quickly put in possession of the essential facts about the behaviour of transistors in practice. Pp. 64. Published for Graetz by Verlag F. W. Rubens, 475 Unna (Westf.), Germany. Price DM 3.80.

Advances in Radio Research, edited by Dr. J. A. Saxton. A new series of collected papers by recognized authorities in their subjects.

Vol. 1. Measurement of radio refractive index of the atmosphere, by A. W. Straiton. Tropospheric refraction and attenuation of radio waves in the troposphere, by B. R. Bean. Electromagnetic surface waves, by James R. Wait. Pp. 226. Price 50s.

Vol. 2. Ionospheric indices, by C. M. Minnis. Antennas and receivers for radio astronomy, by John W. Findley. Radio noise from thunderstorms, by F. Horner. Pp. 215. Price 50s. Published by Academic Press Inc. (London) Ltd., Berkeley Square House, London, W.1.

Intrinsic Electric Strength and Electromechanical Breakdown of Polythene, by R. A. Fava, B.Sc.

Report No. 5044 of the Electrical Research Association investigates the electromechanical compressive forces and strains and describes a technique for their measurement. Modifications for the specimen mounting are suggested which give results closer to the intrinsic strength near the critical temperature (80°C). Pp. 18. Released to members, Feb. 1964, and now generally available from Publications Sales Dept., E.R.A., Cleeve Road, Leatherhead, Surrey. Price 13s by post.

Frequency of Self-oscillations, by Prof. J. Groszkowski. Detailed and extensive analysis of all forms of self-oscillation in linear and non-linear electrical systems, with emphasis on the influence of circuit elements on stability. There is a 50-page section on electromechanical oscillators and a bibliography of references containing 1,900 items. Pp. 530. Polish Scientific Publishers, Warsaw, and Pergamon Press, Headington Hill Hall, Oxford. Price £5.

Electronic Universal Vade Mecum. Vol. 1. Radio Receiving Valves. Vol. 2. Semiconductor Devices and Various Electron Devices. Gives data on devices produced by most of the industrial countries of the world, and contains over 8,000 characteristic curves. Devices having similar or identical characteristics are segregated in over 1,000 different groups according to application. Pp. 1449. Pergamon Press, Headington Hill Hall, Oxford. Price £12.

MANUFACTURERS' PRODUCTS

NEW ELECTRONIC EQUIPMENT AND ACCESSORIES

Anchor-nut Insert

AVAILABLE in a variety of thread types is the new anchor-nut insert from Avdel Ltd., of Welwyn Garden City, Herts. This nut insert—registered Nutsert—can be used on tubes as well as flat material and is simple to fit and, for that matter, easy to remove should it be necessary.

The anchor-nut insert comprises two sections, one of which is threaded and drawn into the other by means of a special tool (see illustration). It can be used on most types of material such as steel, aluminium alloy, glass fibre, plastics, etc., and can be placed in a completely blind hole from one side of the job.

16WW 301 for further details

Stereo Magnetic Pickup Cartridges

THREE new magnetic pickup cartridges from Pickering are announced by the Goldring Manufacturing Company (Great Britain) Ltd., of 486-488 High Road, Leytonstone, London, E.11. All three units are suitable for arms with $\frac{7}{8}$ to $\frac{1}{2}$ in mounting centres, fitted with a diamond stylus, have a channel separation figure of 35 dB and a load resistance of 47 k Ω . The Model V-15, which only weighs 5 grams and is priced at £15 19s 8d, has a tracking weight of 2 to 5 gm; the same in fact as the Model 400AA, which is priced at £33 2s 8d. Both models have an output of 1.5 mV/cm/sec.

The tracking weight of the other, the 481AA is $\frac{1}{2}$ to 3 gm. This one has an output of 0.5 mV/cm/sec and is priced at £40 2s 2d.

16WW 302 for further details

Continuous Tape Transport Mechanism

A NEW deck with a continuous operating tape transport mechanism is being made by Planet Projects Ltd., of Goodman Works, Belvue Road, Northolt, Middx. It runs at $1\frac{1}{2}$ in/sec to provide half-track mono replay facilities for pre-recorded tapes. International recording sense is used, that is to say the top track runs from left to right and bottom track right to left, thus enabling standard equipment to be used for pre-

recording the tapes for use on this deck. The standard models accept seven-inch reels, however modifications can be made to the standard deck to enable smaller reels to be played. Using double-play tape on a seven-inch reel, the length of one cycle is quoted as 8 $\frac{1}{2}$ hours. The retail price is £65.

16WW 303 for further details

Silicon Avalanche Rectifiers on Valve Bases

DIRECT replacements for thermionic e.h.t. rectifiers in the form of silicon avalanche rectifiers mounted on conventional valve bases are announced by the rectifier division of Standard Telephones and Cables Ltd. These units have been found to have a longer life than the equivalent xenon and mercury vapour valves used in radio and television transmission, and besides broadcasting, these units should be particularly interesting to those concerned with industrial applications.

Three types are so far available from S.T.C. These are: Types AV/5R4GY; AV/3B28 and AV/4B32. The first of these is a direct replacement, on an

international octal base, for the 5R4 family of full-wave rectifiers. It is completely encapsulated, has an average anode current capacity of 250 mA, (maximum voltage drop of 2.5 V) and a p.i.v. rating of 1.6 kV. The second of these, the AV/3B28, is a fully encapsulated half-wave rectifier mounted on an American four-pin bayonet base and has a Type CT3 cap. This unit has a p.i.v. rating of 10 kV and an average anode current characteristic of 250 mA (max. voltage drop 10 V).

Suitable for natural or forced-air cooling, the third unit is a half-wave device mounted on a B4F base and has a CT3 cap. Average anode current is quoted as 1.25 A (max. voltage drop 16 V) and the p.i.v. as 10 kV.

All of these units are available from the rectifier division which is based in Edinburgh Way, Harlow, Essex.

16WW 304 for further details

Pulse Generator

A COMPACT pulse generator designed for laboratory and production applications, where pulse repetition rates from 1 c/s to 16 Mc/s (double pulse 8 Mc/s

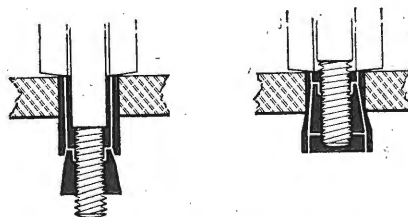

Anchor-nut insert from Avdel Ltd. The illustration on the left shows the threaded cone beginning its entry into retaining sleeve, the other shows it in its final position; the insertion tool has not been withdrawn.

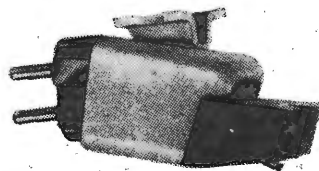

Pickering V-15 magnetic pickup cartridge.

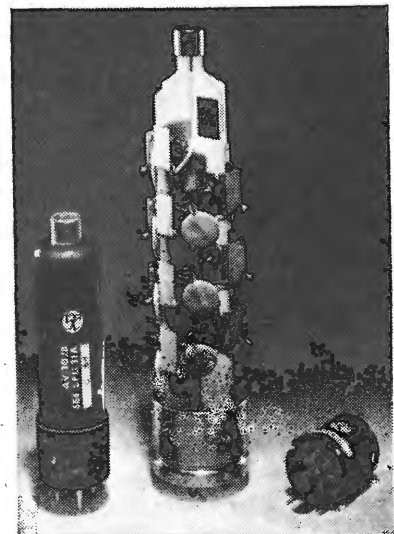

Silicon avalanche e.h.t. rectifiers on valve bases for use as direct replacements from Standard Telephones and Cables Ltd.

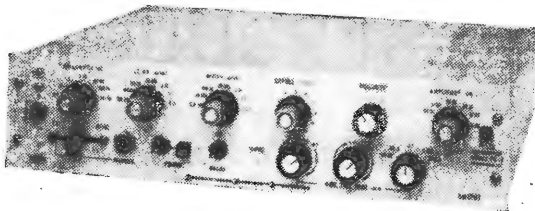

Model PG-2 pulse generator from Inter continental Instruments Incorporated.



Wideband r.f. voltmeter manufactured by the Boonton Electronics Corporation.

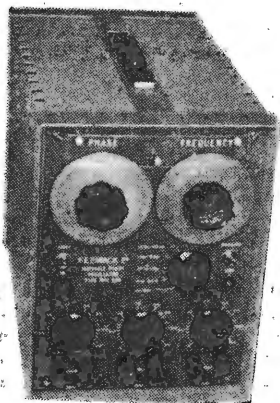

Left:— Variable phase oscillator covering 1 c/s to 100 kc/s (Feedback Ltd.).

Below:—One-watt continuous-wave argon laser from the Raytheon Company.

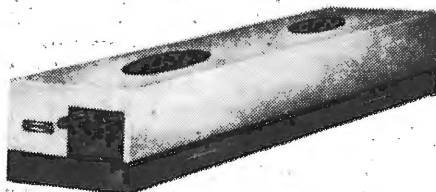

an output stability of 1%. The price is £150.

16WW 306 for further details

Wideband R.F. Voltmeter

AN accuracy of 2% on frequencies up to 100 Mc/s is claimed for an instrument that is capable of measuring voltages from 300 μ V to 300 volts over a frequency range 20 kc/s to 1,200 Mc/s. This instrument, which is manufactured by the Boonton Electronics Corporation, of New Jersey, and handled in this country by Livingston Laboratories Ltd., of 31 Camden Road, London, N.W.1, is known as the 91DA. The accuracy of the instrument at higher frequencies is quoted at $\pm 5\%$ to 400 Mc/s and $\pm 10\%$ up to 1,200 Mc/s. Applications for this instrument include the measurement of high frequency characteristics of transistors and r.f. networks, and v.s.w.r. and return loss measurements of transmission systems. The price is £288, excluding duty.

16WW 307 for further details

One-watt Gas Laser

A CONTINUOUS-WAVE argon laser operating in the single transverse mode at a power of one watt is now available from the Raytheon Company. Known as the Model LG12, its one-watt power output is over the range 4545 to 5145 angstroms in the blue-green portion of the visible spectrum with the principal lines at 4880 and 5145 angstroms.

It is a water-cooled device commercially developed as a result of basic work performed by the Company's research division, which incidentally only recently produced an output greater than one watt during experiments with argon lasers.

A three-phase 60 c/s supply delivering up to 50 amps (that required to obtain 1 watt output) is available to drive the laser head which measures 40 \times 12 \times 10 in. The head itself weighs less than 100 lb, while the associated power supply unit weighs 600 lb.

16WW 308 for further details

are required, is being manufactured by Intercontinental Instruments Incorporated and is available in this country through the instruments division of Claude Lyons Ltd., of 76 Old Hall Street, Liverpool 3 (Southern offices Hoddesdon, Herts). Known as the Model PG-2, this instrument features single or double pulses, positive or negative output up to 20 volts into 50 ohms with adjustable reference, and comprehensive triggering facilities.

Transistors are used throughout the PG-2 giving its rather compact size of only 3½ in in height, 15 in wide (rack-mounting accessories are provided) and an overall depth of 14 in. It weighs 19 lb. Other features of this instrument include adjustable pulse width from 30 nanoseconds to 200 milliseconds, delay from -20 nsec to +20 msec, and independent rise and fall times from 10 nsec to 200 μ sec. The cost of the PG-2 is £369 10s exclusive of duty and surcharge if applicable.

16WW 305 for further details

Variable Phase Oscillator

A VARIABLE phase sine wave generator covering the frequency range of 1 c/s to 100 kc/s is announced by Feedback Ltd., of Crowborough, Sussex. Features of this instrument, which should be of particular interest to those concerned with control, vibration, audio and low

radio frequency work, include three separately adjustable outputs—a reference, a quadrature and a 0° to 360° variable phase.

Two substantially identical stages are used in the oscillator, each producing a phase shift of 90° and are followed by phase inverters to obtain four signals each separated by 90°. These four signals are fed to the cardinal points of a toroidal-wound potentiometer which is compensated to provide an almost linear adjustment of phase angle with displacement. The amplitude varies in fact by about 2% as the wiper traverses each quadrant.

Known as the VPO230, this instrument has a peak output power of 40 mW (5 volts at 8 mA into a 600 Ω load) and

INFORMATION SERVICE FOR PROFESSIONAL READERS

To expedite requests for further information on products appearing in the editorial and advertisement pages of *Wireless World* each month, a sheet of reader service cards is included in this issue. The cards will be found between advertisement pages 16 and 19.

We invite readers to make use of these cards for all inquiries dealing with specific products. Many editorial items and all advertisements are coded with a number, prefixed by 16WW, and it is then necessary only to enter the number(s) on the card.

Readers will appreciate the advantage of being able to fold out the sheet of cards, enabling them to make entries while studying the editorial and advertisement pages.

Postage is free in the U.K., but cards must be stamped if posted overseas. This service will enable professional readers to obtain the additional information they require quickly and easily.

Small Reed Switch

DESIGNED as a companion to the recently introduced Hamlin Type MRG-DT reed switch is the new MTRG-2. This unit is considerably smaller than the MRG-DT, but retains the same environmental characteristics. In fact, the overall length of the MTRG-2 is only 2½ in and the diameter of the glass envelope is only 0.090 in.

It is the same as the MRG-DT in as much as it does not need magnetic biasing, and also it is possible to obtain double-pole changeover, single-pole changeover, and single-pole single-throw combinations. The maximum voltage and current figures quoted for the new device are 28 V and 0.250 A respectively. A life expectancy of ten million operations is given, with a nominal contact resistance of 0.1Ω. These are available from Flight Refuelling Ltd., of Wimborne, Dorset.

16WW 308 for further details

Piston Trimmer Capacitors

THE Stangard range of tubular glass piston trimmer capacitors manufactured by J. F. D. Electronics Corporation, of New York, are now being marketed in the United Kingdom by the capacitor division of Standard Telephones and Cables Ltd., of Brixham Road, Paignton, Devon (or London sales office at Footscray, Kent). These capacitors have a vinyl encapsulation, which protects the glass dielectric against shock, and are

available with two exterior designs; one for panel or chassis mounting and another for printed circuit insertion.

Four different capacitance ranges are available covering 0.5 to 3.0 pF, 0.8 to 5.0 pF, 1.0 to 8.0 pF and 1.0 to 12.0 pF; and all have a working voltage of 1,000 V d.c. Other electrical characteristics quoted include a "Q" figure of better than 1,000 at 1 Mc/s, insulation resistance of 10⁹ MΩ at 500 V d.c. These properties are retained through the temperature range of -55° C to +125° C. Other features of these devices include smooth adjustment torque and multi-turn adjustment for sensitive tuning.

16WW 310 for further details

Digital Distortion Monitor

TO help reduce the number of man-hours now devoted to monitoring operations in telegraph and data link systems, Radiation Incorporated, of Melbourne, Florida, have introduced a digital distortion monitor. Known as the Model 7525, it is designed to operate at any speed in the range 30 to 4,800 bauds. Plug-in crystals are employed to provide an easy means of changing the operating speed of the instrument, which is normally supplied with crystals for operation at 45.5, 50, 55.6, 75 and 150 bauds.

The percentage of distortion is numerically displayed on the front panel of the instrument. When marking distortion is present, the numerals are dis-

played against a red background and space distortion is indicated by a green dial background. The accuracy of the display is quoted to be within 2%.

The unit features a novel alarm output which can be used to actuate recording or counting equipment when the level of distortion in the system exceeds a predetermined level. This, of course, allows the monitored system to be analysed at a later date. The 7525 uses transistors throughout and is suitable for rack or bench use and only requires 3½ in of panel space.

16WW 311 for further details

Subminiature 1-Amp Diodes

SMALL physical size, high surge capacity and ability to withstand high peak transient reverse voltages are features of a new series of subminiature diodes from the International Rectifier Company (Great Britain) Ltd., of Hurst Green, Oxted, Surrey. Designated 10D1 to 10D10, units in the new series are available for industrial and domestic applications where peak inverse voltage specifications of 100 to 1,000 V have to be met. Each unit in the series is rated at 1 amp at 50° C ambient and has a 10 millisecond surge rating of 50 amps.

16WW 312 for further details

Marine Equipment

THREE new marine equipments are announced by the Cossor Communica-

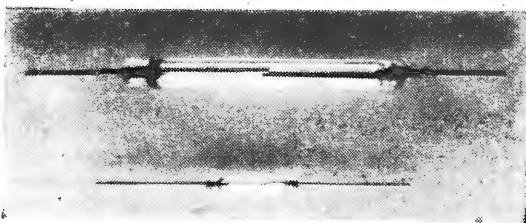

Hamlin reed switches from Flight Refuelling Ltd.

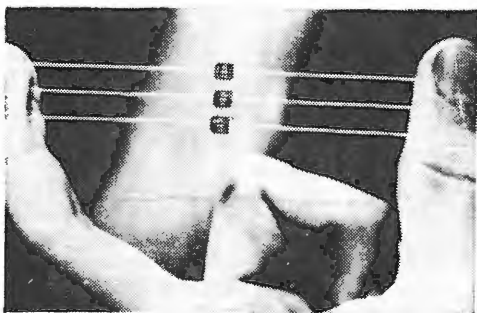

Three subminiature 1-amp diodes (p.i.v. 100 to 1,000 V) from a new series by the International Rectifier Company.



Printed circuit and chassis mounting versions of the J.F.D. Stangard piston trimmers, that are now available through S.T.C.

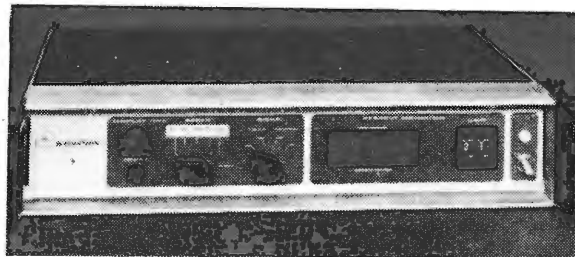

Digital distortion monitor for telegraph and data link systems, from Radiation Incorporated.

tions Company; a ten-inch 20 kW radar, two transceivers and a Loran receiver capable of receiving both the A (1,700 to 2,000 kc/s) and the C (100 kc/s) transmitted signals, the latter which has only recently been introduced and considerably extends the coverage area.

Designated Raytheon 2502 the new 3-cm transistor marine radar has been developed by the Raytheon organization and features a continuously bright picture, which has been achieved through increasing the rotation speed of the aerial, to 80 r.p.m., and the pulse repetition frequency, to a maximum of 6,000 per minute. This enables the screen to be viewed in normal ambient lighting conditions without the need of a visor.

The larger of the two new marine v.h.f. radiotelephones, the CC300M, employs a hybrid circuit of transistors and quick-heat valves to provide almost immediate operation from cold. This unit is crystal-controlled and can provide up to six channels from any 6/12 or 12/24 volt d.c. supply, whilst the other new unit, the CC2/8M is a single channel portable instrument weighing 16 oz. The output of this unit is between 100 to 500 mW (factory pre-set) and meets the requirements of the international marine specifications.

The new Loran receiver employs transistors throughout and was also developed by the Raytheon organization. Known as the Raytheon CA400, the receiver has a sensitivity of 1 μ V for 10 dB quieting and can be used to provide accurate navigational fixes at over 1,000 miles off shore. The maximum power requirements for the CA400 receiver is 32 watts.

16WW 313 for further details

Thermoelectric Probe for Testing Small Components In-circuit

A PORTABLE thermoelectric instrument that enables temperature variations to be effected on small components whilst in circuit is being made by Daystrom Ltd., of Canada, and is available in this country through the Solartron Electronic Group, of Farnborough, Hants. Known as the Thermo-probe TP 10, this unit should prove particularly useful to those in prototype design and development as the range of the probe is from -20° C to $+70^{\circ}$ C, and the response time is two minutes to reach 60% of the final temperature.

Probe tips of various shapes are available to provide maximum thermal contact with the component on trial. In the cooling mode, heat is transferred from the probe tips by conduction to the faces of thermo-electric elements. From here, the heat is pumped to the opposite faces of the elements by applied direct current and then conducted to a cooling

liquid. This liquid is circulated through a liquid-to-air heat exchanger and the heat is transferred to the atmosphere. In the heating mode, the heat flow is reversed by changing the direction of the direct current through the thermoelectric elements. The quantity of heat pumped is a function of the direct current level. Temperature is sensed by a copper/Constantan thermocouple connected to a Weston pyromillivoltmeter. The cost of this instrument is £120, plus the 15% Government surcharge.

16WW 314 for further details

Electrical Stop Clock

A SIMPLE and robust timing device, based on an original design by J. N. Emery, M.A., is now in production by Venner Ltd., Kingston By-Pass, New Malden, Surrey. A clock mechanism with 2½ in dia. seconds dial and two subsidiary 10-sec and 150-sec dials is driven by a 12 V, 50 c/s synchronous motor through an electrically-operated clutch. Contacts provide an output pulse, if required, every second and re-setting to zero can be effected either manually or electrically. Readings can

be made to 1/100th second and the accuracy is that of the power supply frequency. Overall dimensions are 4½ × 3 × 3¼ in and the price is £10 15s. Designed originally for educational experiments in physics this unit will no doubt find many uses in development laboratories.

16WW 315 for further details

Signal Generators for Colour Television

TWO new items of test equipment for colour television are announced by C.F.T.—Compagnie Française de Télévision, of 19 rue Ernest-Cognacq, Levallois-Perret, Seine, France. The first, Type GS-10, has been developed for use in factories for the alignment of SECAM colour receivers, and the second, "Servochrom," is intended for use by the service man in installation and maintenance of SECAM receivers in the field.

Both units employ transistors throughout and the GS-10 generator will supply all the signals necessary to set-up a SECAM receiver in the factory. This includes a series of typical signals, selected by push-buttons, for controlling the various functions of the receiver; a

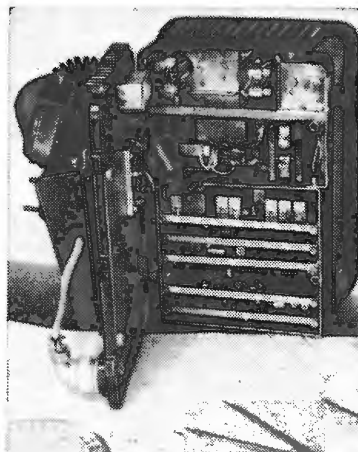

Cosor type CC300M marine radiotelephone.

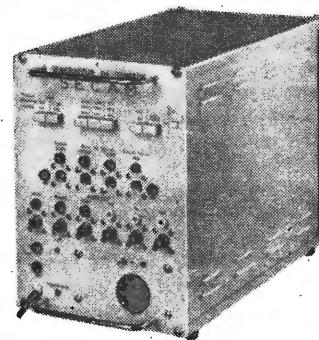

C.F.T. Type GS-10 signal generator for setting up and maintaining SECAM colour television receivers.

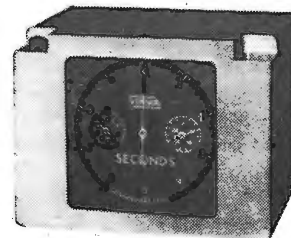
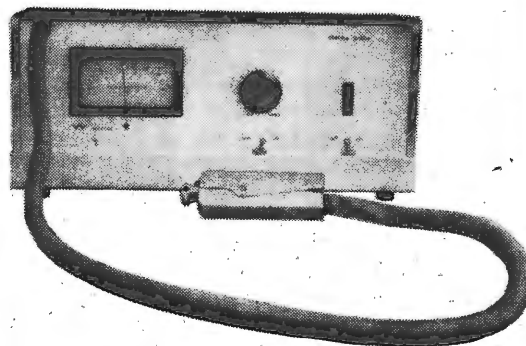

Above:—Venner electric stop clock.

Left:—Thermo-probe for in-circuit testing of small components, available through Solartron.

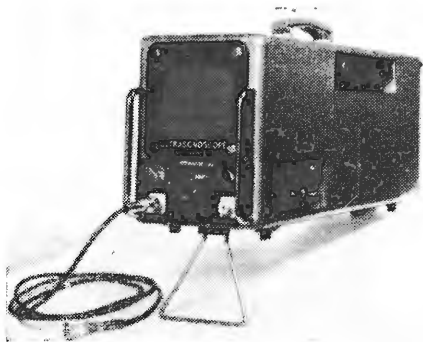

Transistor ultrasonic flaw detector from the Ultrasonoscope Co. (London) Ltd.

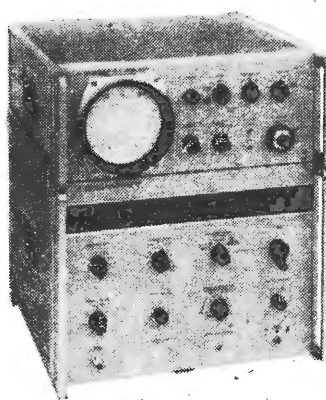

Wideband spectrum analyser from Hewlett-Packard.



Portable d.c. voltmeter and voltage calibration unit manufactured by Electro Scientific Industries Inc., of Oregon, U.S.A.

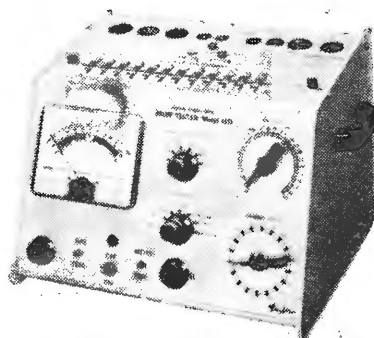

Model 45D valve tester from Taylor Electrical Instruments, of Montrose Avenue, Slough, Bucks.

black-and-white signal to provide a convergence pattern; three bar test pattern primary signals; a SECAM bar pattern signal; and a SECAM coded signal of external primary signals. In fact, when used in conjunction with a synchronizing pulse generator, it can be used to provide a composite SECAM signal.

16WW 316 for further details

Spectrum Analyser with 2 Gc/s Sweep

A NEW spectrum analyser with adjustable sweep bandwidths up to 2 Gc/s, from 10 Mc/s to 40 Gc/s, marks the entry of Hewlett-Packard into this field of instrumentation. Known as the Model 851A/8551A, all basic functions of the instrument are calibrated; spectrum width accuracy is $\pm 5\%$ from 100 kc/s to 3 Mc/s, $\pm 5\%$ at 10 Mc/s and $\pm 4\%$ from 30 Mc/s to 2 Gc/s. The accuracy to which one can set the sweep rate is quoted to be 2% and the resolution is adjustable—manually or automatically—at 1, 3, 10, 100 kc/s or 1 Mc/s. The vertical display is

also calibrated: log, 60 dB (± 2 dB); linear, 70:1 ($\pm 3\%$); and square (power), 70:1 ($\pm 5\%$).

Other features of this instrument, which is designed for rack-mounting and weighs 140 lb, include an internal graticule c.r.t. that overcomes parallax distortion, and a base-line clipper that can be used to eliminate the base-line to facilitate viewing of fast pulses at low repetition rates and to prevent fogging of film when the display is photographed. A signal identifier allows frequencies of an unknown line spectra to be read directly on a slide rule scale. The price complete is £3,643. The company's address is Dallas Road, Bedford.

16WW 317 for further details

Transistor Ultrasonic Flaw Detector

A NEW ultrasonic flaw detector using transistors throughout is announced by the Ultrasonoscope Co. (London) Ltd., of Sudbourne Road, Brixton Hill, London, S.W.2. The fastest timebase speed of this instrument, which is known as

the Mark V, is 2 μ S and enables the whole of the five-inch c.r.t. display to be filled when testing quarter-inch steel. The timebase is continuously variable with a maximum range of 20 feet in steel and the pulse repetition frequency is variable from 50 c/s to 1,000 c/s for the elimination of "ghost echoes."

The instrument is fitted with rechargeable batteries that give the Mark V a life of seven hours at one time in the field. A special mains supply unit that fits in the battery compartment can be supplied to allow the instrument to operate directly off the mains. The price of the Mark V is £650.

16WW 318 for further details

Valve Tester

A NEW valve tester, Model 45D, that supersedes the Model 45C, has been introduced by Taylor Electrical Instruments. The appearance of the instrument has been changed by using a case with a sloping front and an easy-to-read meter. Ten valve bases, including one for nuvistors, are incorporated in the new instrument and enable tests to be carried out on most types of valve. A valve chart that gives test information on over 7,000 British, American, Continental Europe and Russian valves is provided with the instrument.

16WW 319 for further details

Portable Voltmeter and Calibration Unit

A PRECISION d.c. voltmeter and voltage calibration unit manufactured in the United States by Electro Scientific Industries Inc. is now available in the United Kingdom through Livingston Laboratories Ltd. Designated E.S.I. 330, it features an accuracy of $\pm 0.003\%$ of indicated reading and as a voltmeter covers the range 121.110 mV to 1211.10 volts in five ranges. As a voltage source there is three ranges; zero to 121.110 mV in 1 μ V steps, zero to 1.21110 volts in 10 μ V steps and zero to 12.1110 volts in 100 μ V steps. The battery life is 1,000 hours, and the price of the instrument is £312, excluding duty.

16WW 320 for further details

Stabilized Power Unit for Tunnel Diode Logic

A CONTINUOUSLY variable output voltage from zero to 100 millivolts at a current of eight amps, to drive tunnel diode logic circuits, and two auxiliary supplies of +5 and -5 volts at six amps, for associated transistor circuits, are features of a stabilized power supply unit Coutant Electronics Ltd. have designed to match into standard printed

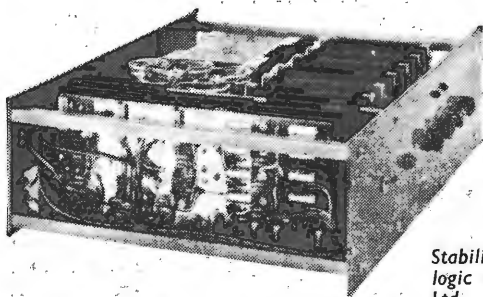

Stabilized power supply unit for tunnel diode logic applications from Coutant Electronics Ltd.

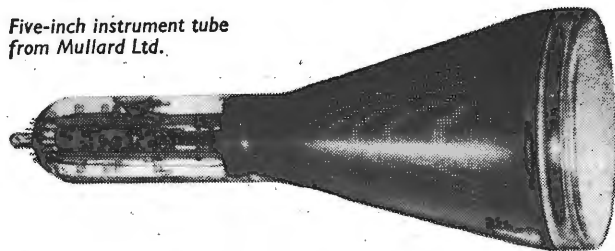

Five-inch instrument tube from Mullard Ltd.

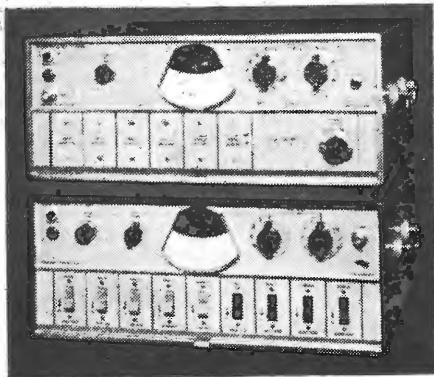

Left:—White noise test set from Marconi Instruments Ltd.

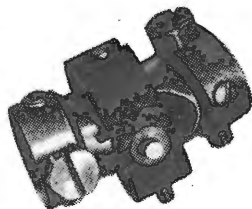

Above:—Miniature component coupling from Oxley Developments.

circuit strip lines. The output connections are, in fact, made by directly soldering the strip lines to a double-sided printed circuit board in the power unit.

To avoid voltage errors at the equipment driven by this unit through line resistance, a sample voltage is fed back to the control amplifier in the power unit's stabilizer circuit via miniature coaxial cables. Silicon semiconductors are used throughout and the unit is designed for use in standard 19-in racking and occupies a panel height of 5½ in.

16WW 321 for further details

White Noise Test Set

DESIGNED for testing cable and radio multi-channel links with capacities of up to 2,700 channels, is the Type OA 2090 white noise test set from Marconi Instruments Ltd., of St. Albans, Herts. It is considerably smaller than its predecessors, through the use of transistors, and comprises two units; a noise generator Type TF 2091 and a noise receiver Type TF 2092.

A special semiconductor diode is employed as the noise source and used to generate white noise to a bandwidth and power level appropriate to the system under test, thus simulating fully loaded conditions. A filter with a narrow stop-band is interposed between the white noise source and the system, which in effect produces a quiet channel. The

receiver section of this test instrument is tuned to this channel and used to compare the noise level produced by intermodulation of the white noise occupying the remainder of the frequency band with the original signal in the channel.

Up to nine "quick-change" filters—each containing band-limiting and band-eliminating filters—are incorporated in the generator. These units include switches with colour-coded toggle-keys to simplify operation. The receiver unit has provision for up to six spot frequencies and also employs interchangeable filter units, which correspond to the generator band-stop filter frequencies.

16WW 322 for further details

Five-inch C.R. Tube

AN addition to their range of oscilloscope cathode-ray tubes is announced by Mullard Ltd. in the form of a five-inch tube. This tube has an overall length of under 14 in and should be of particular interest to designers of small general purpose oscilloscopes and of equipment with "built-in" monitoring facilities. Designated D13-27GH, it has a flat-faced, medium persistence green phosphor screen with a helical post-deflection accelerator.

In common with other recently introduced Mullard tubes, a separate electrode arrangement permits direct beam blanking and this particular tube only requires a deflection voltage of 60 (maxi-

um) to effect this at the normal 3 kV operating voltage. The deflection sensitivity, also under 3 kV operating conditions, is better than 27 V/cm for the X direction and 13 V/cm for the Y direction; the minimum picture size is 10 × 8 cm.

16WW 323 for further details

Miniature Coupling

A COMPONENT coupling with p.t.f.e. bushings, which the manufacturer's claim reduces friction and eliminate wear, is announced by Oxley Developments Co. Ltd., of Ulverston, Lancs. Designed for use on standard ¼-in diameter shafts, this coupling will provide 5° angular and ⅜ in axial displacement, and will transmit a torque of 15 oz per in.

16WW 324 for further details

Light-emitting Diode

A FORWARD-BIASED gallium phosphide diode suitably doped to produce electroluminescent radiation of 7,000 angstroms (red) is being manufactured by the electronics department of Ferranti Ltd., of Gem Mill, Oldham, Lancs. The device, which is claimed to be the first of its type to be manufactured in the United Kingdom, is based on radiation due to the effect of the re-combination of electron-hole pairs at a p-n junction. It is encapsulated in transparent plastic and measures 0.030 × 0.040 in.

Average steady brightness of 10 to 40 lamberts is achieved by feeding it with 50 mA pulses of one millisecond duration. Current can be increased to improve the light intensity at the junction and a 1-A 1 μ sec pulse gives an increase of twenty times over the steady-state brightness. Switch-on time of the device is around 0.2 μ sec and the operating temperature range is -20°C to +70°C.

This device can also be operated in the reverse biased mode to act as a fast light source; light output rise times of less than three nanoseconds can be obtained.

The Services Electronics Research Laboratory sponsored the development of this device and were responsible for all of the initial research work.

16WW 325 for further details

LETTERS TO THE EDITOR

The Editor does not necessarily endorse opinions expressed by his correspondents

Television Distribution by Wire

IT is perhaps unfortunate that Mr. Kinross, in his contribution "Television Distribution by Wire," has deviated from a truly technical exposition into the realms of relay politics. For a start, one would expect from the title that a full discussion of all types of relay systems was to follow, but instead we are presented with a somewhat summary dismissal of v.h.f. systems and a lengthy, though interesting, song of praise for the h.f. distribution system. In view of this, would it not seem that the title to the article is a trifle misleading, particularly to those who know little about the television relay business?

H.f. relay networks were born out of necessity in the post-war revival of the television service, the days of double-sideband on Channel 1. Many of the old audio-only networks were faced with financial ruin unless video could be also distributed, and h.f. was chosen in preference to re-wiring a whole network!

V.h.f. systems were born out of a desire to improve upon the old distribution methods and have reached a highly advanced stage of development. They were also introduced to break the monopoly then existing wherever h.f. distribution systems were operating with their special "relay-only" sets. I would suggest that the competition from v.h.f. systems has forced the h.f. relay company to gradually make concessions to the television retailers over the receiver side of their business.

Would somebody please tell Mr. Kinross and the rest of the world about the large systems using British-made v.h.f. relay equipment that exist in Europe and North America? Let us not forget that Britain is not the only country where wired distribution systems serve a good proportion of the viewing community.

Lastly, a word about the special receivers. It is all very well to state that the purchase price of a 19in wired receiver is £21 less than that of an average cheap aerial receiver, but what happens to the purchaser of one of these sets when he or she decides to move house? People have been known to move! Furthermore, a breakdown on the relay network would leave subscribers with blank screens, whereas the subscriber with the standard receiver could get some sort of picture until the fault is rectified.

Brentwood, Essex.

G. M. YOUNG

Resistances and Reactances in Parallel

I CAN hardly believe that the following simple construction for the impedance of a resistance and a reactance in parallel is not common knowledge, and yet in all my reading I have not come across it.

Fig. 1 shows a resistance R and a reactance jX plotted on an impedance diagram.

The impedance Z_s obtained by connecting R and jX in series is got by "completing the parallelogram" (in this case a rectangle), and is shown on the diagram.

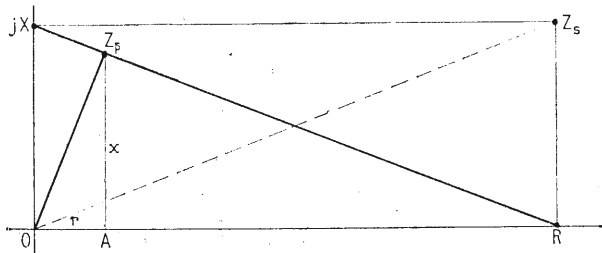

Fig. 1

The impedance Z_p obtained by connecting R and jX in parallel is found by dropping a perpendicular from the origin to the line joining the points R and jX, and is likewise shown on the diagram.

The proof is quite simple. If r and x are the resistive and reactive components of Z_p , we have to show that:

$$r = X^2R/(R^2 + X^2) \text{ and } x = XR^2/(R^2 + X^2),$$

that is, that:

$$x/r = R/X \quad \dots \quad (i)$$

and that:

$$r^2 + x^2 = (X^4R^2 + X^2R^4)/(R^2 + X^2)^2 = X^2R^2/(R^2 + X^2) \quad \dots \quad (ii).$$

These relations follow from the fact that a resistance R in parallel with a reactance jX form an impedance

$$\frac{R \cdot jX}{R + jX}, \quad \text{which when rationalized becomes } \frac{X^2R/(R^2 + X^2) + jR^2X/(R^2 + X^2)}{R^2 + X^2}.$$

Thus

$$r = X^2R/(R^2 + X^2) \text{ and } x = R^2X/(R^2 + X^2).$$

The triangles OR(jX) and OAZ_p are similar, therefore AZ_p/OA = OR/O(jX). This proves relation (i).

The triangles ORZ_p and OR(jX) are also similar, therefore OR/OZ_p = R(jX)/O(jX), thus

$$R/(r^2 + x^2)^{1/2} = (R^2 + X^2)^{1/2}/X,$$

therefore:

$$r^2 + x^2 = X^2R^2/(R^2 + X^2), \text{ which is relation (ii).}$$

A similar construction holds for a conductance and a susceptance in series. Fig. 2 shows how to obtain the conductive

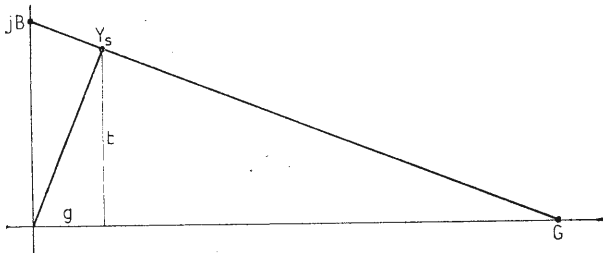

Fig. 2

and susceptive components, g and b, of a conductance G connected in series with a susceptance jB. The diagram is an admittance diagram, and Y_s is the admittance of G and jB in series.

The proof of this case follows similar lines as in the one given above.

In each of these cases, if the values of R and X, or of G and B, are at all awkward, the method described here using a sheet of graph paper and a set square is very much quicker and easier than the calculation.

Manchester

G. HOFFMANN DE VISME

Practical Transistor Circuit Design

MR. HOBBS (p. 619, Dec. 1964 issue) appears to have missed the point of my criticism in my last letter, so I would like to explain the reasoning behind my arguments.

To describe the performance of a three-terminal active network, a set of four mutually independent parameters is generally required. The h, y, and z parameters are three such sets. The sets are interrelated by exact algebraic expressions.

The equivalent-T network also has four independent parameters, r_b, r_e, r_c and α (or β), which are completely com-

patible with the h parameters, and represent the three-terminal "black box" just as adequately. In addition, the T configuration provides a guide to the internal workings of the transistor.

Examination of the hybrid- π network as used by Mr. Hobbs shows that, by neglecting $r_{b'b'}$, there are only *three* independent parameters. It therefore does not give an adequate description of the three-terminal network, let alone the internal transistor mechanism. A look at the input resistance of the grounded-emitter stage—with the collector short circuit and open circuit illustrates this point:

$$\text{In h parameters, } R_{in(RL=0)} = h_{11}, R_{in(RL=\infty)} = h_{11} - \frac{h_{12}h_{21}}{h_{22}}$$

$$\text{In T parameters, } R_{in(RL=0)} \approx r_b + \beta r_e, R_{in(RL=\infty)} \approx r_b + r_e$$

$$\text{In hybrid-}\pi \text{ parameters, } R_{in(RL=0)} \approx r_{b'e}, R_{in(RL=\infty)} \approx \frac{r_{b'e}}{2}$$

The significant point is that in the hybrid- π case, both values of input resistance use only the parameter $r_{b'e}$. An independent parameter must be discarded from the other two systems to make them compatible with the π system, in which the lack of generality is inherent. I can see no justification for discarding a parameter, *as* such a practice is not an approximation, but an omission! It is worth looking at an actual transistor to show this. The transistor type 2N3114 has typical h parameters quoted at $I_c=1.0\text{mA}$ and $V_{CE}=5.0\text{V}$, which are:

$$h_{11} = 1,500\Omega$$

$$h_{12} = 1.5 \times 10^{-4}$$

$$h_{21} = 50$$

$$h_{22} = 5.3 \times 10^{-6} \text{ mho}$$

From these figures it is easily shown that

$$R_{in(RL=0)} = h_{11} = 1500\Omega.$$

$$R_{in(RL=\infty)} = h_{11} - \frac{h_{12}h_{21}}{h_{22}} = 1500 - \frac{1.5 \times 10^{-4} \times 50}{5.3 \times 10^{-6}} = 85\Omega.$$

The ratios of these two values is almost 18, somewhat different to the value of 2 predicted by Mr. Hobbs!

The factual criticisms in my previous letter were based on the above arguments, and still, I think, hold good. I was unable to follow Mr. Hobbs' line of reasoning in his reply.

Camberley, Surrey

M. TILEY

The author replies:—

I am grateful for Mr. Tiley's numerical example and agree that I am using simplified equations for the hybrid- π equivalent circuit. In the hybrid- π circuit there are, in fact, *five* parameters: $r_{e'e}$, $r_{b'b'}$, $r_{b'e}$, $r_{b'b}$ and β , and whilst four parameters are required to describe a three terminal active network, the equivalent circuit used as a guide in design can, if it helps, have more than four elements. I drew attention in the September issue to the difference between the component elements of an equivalent circuit and the h-parameters (or y or z parameters) which describe the "black box" externally.

Of course, one can always work out exact algebraic relations between these two, and the input resistance can be expressed in terms of either. As Mr. Tiley says, R_{in} for $R_L=\infty$ is h_{11}

$$- \frac{h_{12}h_{21}}{h_{22}}. \text{ First rewriting the expression as } R_{in} =$$

$$h_{11} \left(\frac{1 - h_{12}h_{21}}{h_{11}h_{22}} \right) \text{ and substituting the typical values for the}$$

2N3114 we do get $R_{in} = 1.5\text{k}\Omega(1 - 0.943) = 85 \text{ ohms}$. Now

my approach effectively adopts a value of 0.5 for $\frac{h_{12}h_{21}}{h_{11}h_{22}}$

(for reasons which I explained in my previous letter). It is my assumption as regards $r_{e'e}$ which leads to the difference in our results and not my neglect of $r_{b'b}$ (this can always be added in when significant). In the equivalent -T network $r_{b'b}$ forms part of r_b .

I am concerned about the figure 0.943 and suspicious of substituting a set of typical values into the expression when obviously a small change in any one of the parameters will make a wide difference to the calculated magnitude of R_{in} . Are the typical values a result of taking a mean for each parameter over a large number of samples or are they in fact a consistent set in themselves?

To satisfy the figures as a set, the components of the hybrid- π circuit need to take the values: $\beta=50$, $r_{b'e}=1.5\text{k}\Omega$, $r_{b'e}=\infty$

$9.5\text{M}\Omega$ and $r_{e'e}$ needs to be very large depending on the value taken for $r_{b'b}$ —about $11\text{M}\Omega$ when $r_{b'b}$ is 30 ohms, for instance. The maximum voltage gain is apparently very high—111,000—and, examined in terms of the hybrid- π circuit it is Miller feedback which makes the input resistance turn out so low for $R_L=\infty$. If these figures are to be believed, the output resistance should also vary over a range of 18 to 1 for R_s going from zero to infinity. It is not too difficult to measure a variation of putput resistance and in my experience (for say the ASY29 or 2N708) the factor is never more than two or three to one so that my simplified equations give a good representation of a practical device.

G. P. HOBBS

Cone Surrounds

WHILST searching for the cause of a variable low level distortion and loss of bass in my gramophone system I was finally and reluctantly forced to examine the loudspeaker which, since it carries a renowned name, I had hitherto regarded rather like Caesar's wife as beyond suspicion. To my amazement I found the foamed plastic surround was completely perished. Knowing that this material will last much longer than the seven years that the speaker had been in use, I looked for some unlikely cause. A clue was given by a colleague who suggested that the foamed material acted as a leaky valve and that the smoke from my cheroots had been pumped through and caused the disintegration. Accepting part of his suggestion it seemed more likely that something had been pumped from inside the wooden structure. There seemed to be two possibilities: some vapour had been given off either by the block board itself, or by the glue I had used to hold it together. The latter was an epoxy resin and sure enough the hardener when poured on some of the remaining suspension went through it in a truly proverbial manner.

This letter is not, of course, intended as an indictment of the makers of either the glue or the loudspeaker, both of which products are beyond reproach, but as a warning to future wooden horn builders to be on their guard, since other cone suspensions and synthetic glue vapours may react similarly.

Gidea Park.

FRANK ROADS

Equalizing in Audio Pre-amplifiers

A CIRCUIT which is frequently found in the first stage of an audio pre-amplifier is that shown in the diagram below.

Here, a number of different inputs: radio, tape, microphone, gramophone pickup, etc., can be catered for by a simple switching arrangement, and the desired equalizing, input impedance, and sensitivity can be obtained by switching in suitable different values of R_1 and Z for each case. In this way the signal level at B is made roughly the same whatever input is being used, thus easing design problems in the rest of the pre-amplifier.

The desirability of carrying out the equalizing in this way in cases where the sensitivity needs to be high (as when handling the output of a tape replay head or a ribbon microphone) has been questioned by seekers after the ultimate, because the S/N ratio obtained is necessarily worse than that in the alternative arrangement where the input is connected

directly to the valve grid, and the equalizing is done in a later stage.

The writer recently had occasion to compare the two circuits theoretically and made the discovery that the noise level of the feedback type of circuit need not be as high as it often is.

Point A in the circuit is a virtual

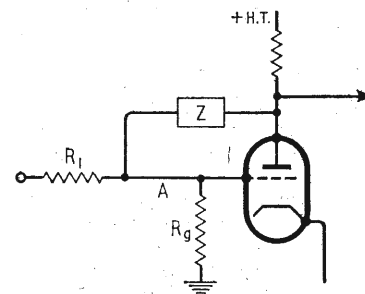

earth (low impedance point) as far as the input is concerned, and therefore it might be thought quite in order to make the value of the grid leak R_g relatively small. If this is done, it certainly has no effect on the performance of the circuit as far as the input signal or any unwanted signals picked up by the input circuitry are concerned. However, if one considers the effect of the feedback on the shot noise generated *inside* the valve (which is the prime cause of the noise background of the ultimate output), it is easily shown that R_g affects the noise level at B, since the more noise fed back, the less there will be at the output. It therefore pays to make R_g as high as possible.

In a circuit used by the writer for tape replay, the valve is an EF 86, $R_1 = 56 \text{ k}\Omega$, and Z consists of 330 pF in series with $390 \text{ k}\Omega$. The original design value of R_g was $100 \text{ k}\Omega$. In this case a slight noise background was noticeable. R_g has been increased to $2.2 \text{ M}\Omega$, and the noise background is now negligible. The theoretically expected improvement in this case was 4 dB.

In a similar published circuit intended for a microphone input, $R_1 = 1 \text{ M}\Omega$, and Z consists of $0.1 \mu\text{F}$ in series with $10 \text{ M}\Omega$. The writer does not at present use this particular circuit, but here the theoretical improvement in S/N due to changing R_g from $100 \text{ k}\Omega$ to $2.2 \text{ M}\Omega$ is 17 dB.

Bournemouth

F. B. JOHNSON

W.W. Transistor FM Tuner

I HAVE found that the following modification to this circuit gives improved reception in areas of low signal strength (10 to $15 \mu\text{V/m}$), by substantially reducing the background noise.

When the input to the Schmitt trigger is around the limit-

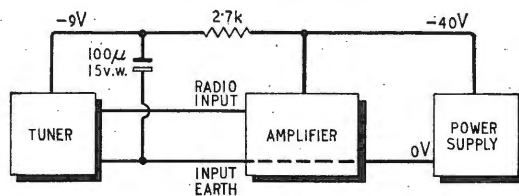

ing value of 300 mV , the h.f. ripple on the standard 130 kc/s signal is of sufficient magnitude to cause intermittent operation of the trigger circuit, producing a harsh crackling background. This h.f. may be reduced by connecting a small capacitor directly across R_{10} ($6.8 \text{ k}\Omega$) at the input to the i.f. amplifier. The optimum value may vary with individual conditions but 1000 to 2000 pF has been found to give good results. It is easy to incorporate this capacitor whether pin or printed-circuit construction is used.

Incidentally, this tuner is ideal for use with the transistorized high-quality amplifier (both the old, and the new version described in this issue), since the sensitivity and input impedance of the radio input are about 100 mV and $100 \text{ k}\Omega$ respectively. The power supply may be taken directly from the -40 volt amplifier supply via a $2.7 \text{ k}\Omega$ dropping resistor (my tuner requires 11.8 milliamps) and decoupled by $100 \mu\text{F}$. However, it is important to take the earth return (including the capacitor) to the signal earth line at the input terminal (as shown) and not to the power supply. This will ensure that the very low hum and distortion levels of both circuits are maintained.

Farnborough, Hants.

J. DINSDALE

Colour Correspondence Course

WHEN colour television eventually arrives in Britain many of us will have to supplement our knowledge of general principles with a great deal of hard, factual information on the operation of equipment, particularly colour receivers. Those in greatest need, of course, will be the service technicians. Anybody who wishes to prepare himself in advance of the actual event can now do so by taking advantage of a home study course in colour television made available in the U.K. through RCA Great Britain Ltd.

The great advantage of the course is that it is based on 11 years' experience of broadcasting and receiving colour television in the U.S.A. Its main limitation is that the more specific information provided is tied to the N.T.S.C. system, as operated on American standards, and to American receivers and test equipment. This limitation is perhaps not as serious as it sounds, however, since two out of three of the contending systems in Britain (N.T.S.C. and PAL) are very similar to American N.T.S.C., and many of the circuit techniques now being used in American receivers would certainly be adapted to British requirements (the set makers having already seen to this) if one of these two systems were to be adopted.

The course, which costs £20, is contained in eight lessons: principles; colour tubes; receiver functions; setting up and adjustment; circuitry; alignment; fault tracing; and test equipment. These are presented in four books, with a binder for holding them together. The explanatory material is well written and the diagrams are clear and informative (though some of the receiver circuits are a trifle cramped). Each lesson is followed by an examination paper of 20 questions, couched in the following typical form:

"The instantaneous output of one of the chrominance demodulators is zero when the phase difference between the chrominance signal input and the CW signal input is (a) 0° ; (b) 90° ; (c) 180° ; (d) 57° ?"

Completed examination pages have to be sent to RCA Great Britain for marking, after which they are returned.

A companion RCA publication on colour, intended specifically for the service technician, is a 153-page, hard-cover book entitled "Colour TV Troubleshooting Pict-o-Guide."

Designed as a compact and easy-to-use handbook, on the principle that "pictures tell the story best," it contains over 130 colour photographs taken from tube screens, illustrating the effect on the picture of various receiver conditions and faults. The price is £2 10s including postage.

The home study course booklets in their binder, with, in front, the "Pict-o-Guide" for fault finding.



LOGIC WITHOUT TEARS

AN INTRODUCTION TO SWITCHING ALGEBRA

By H. R. HENLEY, A.M.I.E.R.E.

IN 1854 George Boole published his paper: "An Investigation into the Laws of Thought", in which he developed his algebra of Logic or as it is now widely known, in his honour, Boolean algebra. Little did he realize at that time that his work, intended to facilitate the processes of mathematical research, would be used so extensively for such "impure" mathematical applications as digital computing and control engineering.

Development of a switching algebra from Boolean algebra usually involves fairly rigid mathematical methods of reasoning. This is very well for an elaborate treatise on the subject, but is considered unnecessary for this article in which it is intended only to provide an introduction to the subject. For this purpose an almost Lewistic approach will be used to develop the few rules necessary to carry out analysis and synthesis of simple switching systems.

Switching systems may take many forms, e.g. an automatic telephone system using thousands of relays, etc., or a digital computer using semi-conductors; both to perform switching operations on a logical basis. In either of these examples, and in the general case we are concerned with statements about the system which, at any instant, may be two-valued, i.e. true or false, for example, whether a given potential is present or absent from a wire, whether a given path is conducting or non-conducting, and so on.

Suppose a wire A may have either 10 volts or zero volts on it. Then the statement "Wire A is at 10 volts" may be either true or false, depending on whether 10 volts is present or not. A convenient symbolism may be used; we can assign the value 1 to the statement if it is true and say $A=1$, and the value 0, i.e. $A=0$, if the statement is false.

In forming statements to describe the operation of a system we inevitably use (or imply the use of) the connectives AND, OR and NOT. By suitable choice of language any statement can be rephrased in these terms and for this reason the algebra to be described is based on them. For instance in a system we might have the condition that "an output voltage level of 10 volts is obtained on wire F only if wires A and B are at a potential of 10V but not wire C, or if wires A and C and D are at zero volts." Clearly this form of specification becomes unwieldy and a symbolic method is desirable if only to enable one to see the "wood as well as the trees."

To do this we postulate three operations AND, OR and NOT, borrowing the symbols \times and $+$ from ordinary algebra for the first two and putting a bar $\bar{\quad}$ over a symbol to indicate negation, e.g.:

$A + B$ reads A or B.

AB or $A \cdot B$ or $A \times B$ reads A and B

\bar{A} reads NOT A and is also called the complement of A. It follows that $1 = 0$, i.e. Not true = false and *vice versa*.

Since we are using (some) algebraic symbols and writing

algebraic-looking equations it is only reasonable to see whether any of the rules of ordinary algebra will be of any use in this algebra. To decide this, for simplicity, we shall use simple logic circuits made up of relay contacts [the relay coils will not be shown] and denote by S the statement "The circuit through the switching network is continuous." When this is true, $S = 1$.

First consider the parallel net of contacts A, B and C (Fig. 1).

The network is continuous if A, or B or C is operated.

Therefore $F = A + B + C$

Clearly $F = A + C + B$ or $C + A + B$ etc., i.e. the order in which the contacts are considered (or wired) does not alter the truth of the statement.

Similarly for the series net (Fig. 2).

The network is continuous only if A and B and C are operated simultaneously.

Then $F = A \cdot B \cdot C$

and again the order is unimportant.

This is a convenient point at which to introduce a useful device called a truth table. This is simply a table showing the possible values of the variables A, B, etc. and the resultant values of F. For example, consider the second function above, $F = A \cdot B \cdot C$; the truth table is shown in Fig. 3.

This shows that $F = 1$ only when $A = B = C = 1$.

It is desirable to adopt a systematic method of writing down the possible values of the variables. This is most simply done by the method used above. In the first column write alternate 1's and 0's. In the second write alternate pairs of 1's and 0's. In the third write alternate quadruples of 1's and 0's. In the n'th column (for n

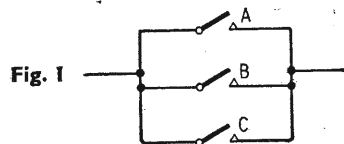

Fig. 1

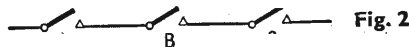

Fig. 2

A	B	C	F
0	0	0	0
1	0	0	0
0	1	0	0
1	1	0	0
0	0	1	0
1	0	1	0
0	1	1	0
1	1	1	1

Fig. 3

variables) write 2^{n-1} 1's followed by 2^{n-1} 0's. Only 2^n rows are necessary.

The significance of the NOT or complement function should perhaps be clarified in the case of relay contact networks. If we have a circuit in which $S = A$, then A is clearly a "make" (or normally made) contact, and $S = 1$ when $A = 1$ (i.e. when A is operated). If $S = \bar{A}$ then $S = \bar{A} = 1$ when $A = 0$, i.e. when the contact is operated it must present an open circuit. This requirement is satisfied by a "break" (or normally closed contact). The convention is used in which contacts are shown in the normal (unoperated) state [in accordance with B.S. 530].

The truth table for A and its complement \bar{A} is simply:

A	\bar{A}
1	0
0	1

Two other rules are the distributive laws of OR and AND, they are:—

$$A(B+C) = AB+AC \dots(1)$$

$$A+BC = (A+B)(A+C) \dots(2)$$

Rule (1) is similar to ordinary algebra, but (2) has no equivalent in ordinary algebra.

Also from the definitions of AND and OR, 1 and 0, it follows that:—

$$\begin{aligned} 1+1 &= 1 & A.A &= A \\ 1+0 &= 1 & A+A &= A \\ 1 \times 1 &= 1 & A+1 &= 1 \\ 1 \times 0 &= 0 & A.1 &= A \end{aligned}$$

All of the above may be verified using the truth table.

Attention is drawn to the fact that operations similar to division and subtraction do not exist, and cannot be used in simplifying equations. e.g. it is not possible to conclude that if $A+BC = A+D$, say, then $BC=D$ by subtracting A on each side as in ordinary algebra. Such operations are *undefined* and therefore have no logical meaning.

One very important property of the algebra is its duality. The dual of 1 is 0; the dual of A is \bar{A} ; the dual of AND is OR; and *vice versa*. This is exemplified in rules 1 and 2 above;

$$A(B+C) = AB+AC \dots\dots\dots (a)$$

$$A+BC = (A+B)(A+C) \dots\dots\dots (b)$$

in which + and \times are interchanged in (a) to give (b) and *vice versa*. This is stated generally in the Duality Law: "If a theorem is valid, so too is its dual."

In general the dual of an equation is found by interchanging + and \times , and 0 and 1.

The above rules are used to prove other relationships and to simplify expressions describing complex switching circuits. Before dealing with examples of these we must first consider a more general way of depicting logical operations diagrammatically. This is desirable since the use of relay contacts, as hitherto, would be unnecessarily restrictive. In most of the applications of switching algebra, electronic devices rather than relays are used and the translation of a relay diagram, into its equivalent using, say, transistors may be long and tedious. In many applications a standard transistor circuit may be used to perform each of the three functions (or combinations, e.g. NOT-AND) rendering realization of the final circuit a simple matter, if a system of symbols is used to represent logical operations.

The system used here is that recommended by B.S.530.

The AND and OR functions are both represented by circles with a number of input wires and one output wire. The number within the circle indicates the number of inputs which must be simultaneously at 1 for the out-

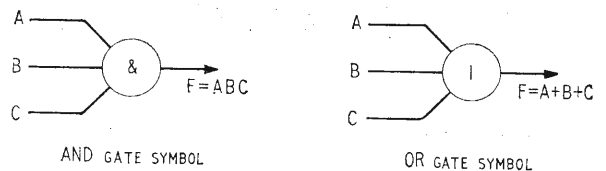

Fig. 4

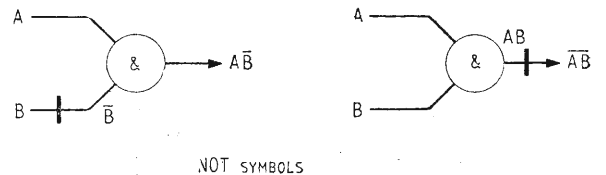

Fig. 5

put to be 1. Clearly for the AND function this number will be equal to the number of inputs, whereas for the OR function it will always be 1 (Fig. 4).

These are called, generally, gates rather than the term "circuit" used hitherto. Thus the AND gate is said to be open when all inputs are 1, and closed if one or more are at 0.

NOT is represented by a short bar drawn across a signal lead (Fig. 5).

When it is desired to show that a physical logic element is performing the NOT function, the following symbol is used:—



We shall now consider a few examples which are useful in reducing equations to simpler forms—this is referred to as "minimization"

$$\begin{aligned} F &= A + AB \\ &= A.1 + AB \\ &= A(B + \bar{B}) + AB \\ &= AB + A\bar{B} + AB \text{ using the distributive rule for AND} \\ &= AB + A\bar{B} \text{ since } AB + AB = AB \\ &= A(B + \bar{B}) = A.1 = A \end{aligned}$$

This is a startling result since this suggests that the original circuit can be replaced by a direct connection, i.e. all circuit elements are redundant and input B does not affect the final output. The truth of this result may be verified by means of a truth table (Fig. 6).

A	B	AB	A+AB
1	1	1	1
0	1	0	0
1	0	0	1
0	0	0	0

Fig. 6

The first and last columns of the table are identical, verifying that the circuit may indeed be replaced by a direct connection.

In terms of the logic diagram this means that in Fig. 7 (a) can be replaced by (b).

The dual of this is $A(A+B) = A$ which may be proved in the same way.

Another pair of dual theorems which are useful in minimization are:—

$$\begin{aligned} A(\bar{A}+B) &= AB \\ A+\bar{A}B &= A+B \end{aligned}$$

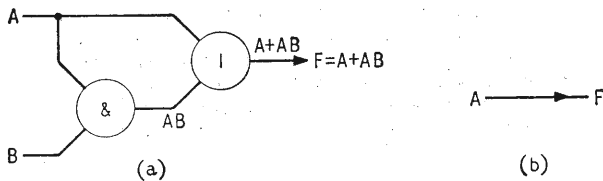

Fig. 7

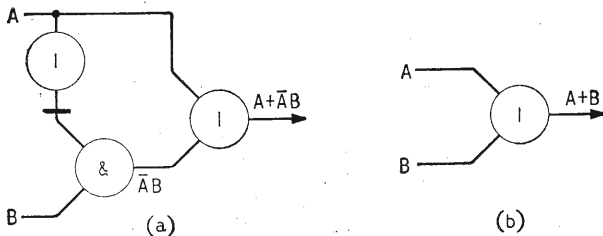

Fig. 8

In the second equation of the pair,
 $A + \bar{A}B = (A + \bar{A})(A + B)$ (using the Distributive law for OR)
 $= 1 \cdot (A + B)$
 $= A + B$

They may both be verified by means of a truth table. In terms of logic circuits, the simplification is shown in Fig. 8, where (a) can be replaced by (b).

This results in a saving of one AND gate and a device for producing \bar{A} , which, as we shall see represents a considerable economy in a large installation where the above circuit may be used in quantity.

De Morgan's Theorem:—This is an important theorem both in analysis and synthesis of logic circuits particularly in the realization of circuits using NAND and NOR (NOT-AND and NOT-OR) logic. The theorem states:—

$$\overline{AB} = \bar{A} + \bar{B}$$

and by duality $\overline{A + B} = \bar{A} \bar{B}$

These statements are fundamental to Boolean algebra; we shall verify the first by means of the truth table (see Fig. 9).

The last two columns are identical, verifying the

A	B	\bar{A}	\bar{B}	\overline{AB}	$\overline{A + B}$
1	1	0	0	0	0
0	1	1	0	1	1
1	0	0	1	1	1
0	0	1	1	1	1

Fig. 9

A	B	C	F
1	1	1	1
1	0	1	0
0	1	0	1
1	0	0	0

✓ $F = ABC$
 ✓ $F = \bar{A}\bar{B}C$

Fig. 10

A	B	F
1	1	0
0	1	1
1	0	1
0	0	0

✓
 ✓

Fig. 11

theorem. It is left to the reader to repeat this for the dual form.

From this the following may be derived.

$$\overline{AB + CD} = (\bar{A} + \bar{B})(\bar{C} + \bar{D})$$

and $\overline{(A + B)(C + D)} = \bar{A}\bar{B} + \bar{C}\bar{D}$

It is seen that De Morgan's theorem is a more general expression of the Duality Rule which we dealt with earlier.

Synthesis:—We are now in command of sufficient knowledge to tackle the subject which is probably of most interest, that of synthesis of control circuits.

The problem in general is to design a logic event which will control a device or devices in a certain prescribed fashion when its inputs are in certain allowed states. For example, a passenger lift control system, which must determine whether or not the gates are closed; which floor is calling, or has been selected by a passenger; whether it is operator or passenger controlled etc. In general such systems fall into two broad classes—combinational and sequential. The first class will be dealt with here and concerns those circuits in which the outputs correspond to certain input combinations. The second class of circuit involves another element—time. The circuit outputs are functions of the inputs and the previous state of the circuit. This subject is beyond the scope of the present article.

The requirements of a combinational logic system are usually stated, as in the above case, in words. This has to be translated into a truth table which relates the input and output devices. From this table we derive equations relating the inputs and outputs. The process employed is derived from the theory for expansion of equations into their canonical forms and is simply this:

Mark each row of the truth table for which the output is true (i.e. 1). Now write down the product of the input functions for each of these rows, writing the function when its truth value is "1" and its complement when it is "0". Now add the separate products and equate to the output function.

For example, if the truth table for a system is required to be as shown in Fig. 10 we select rows (1) and (3) since F has the truth value 1, and from the sum of products:

$$F = ABC + \bar{A}\bar{B}C$$

As a simple example let us consider the exclusive OR circuit. This differs from the simple inclusive OR dealt with earlier in that it excludes the condition A and B simultaneously 1. The required operation is that the output is 1 if A=1 or B=1 but NOT A and B=1. The truth table is shown in Fig. 11

Now the output $F = 1$ in rows 2 and 3, and the required equation is therefore:—

$$\bar{A}B + A\bar{B} = F$$

In general the equation obtained from the truth table will be more complex than in this example and it is first necessary to apply one or more of the rules in order to reduce it to its simplest form. Having reached this stage, all that remains is to translate the algebraic expression into a logic diagram.

To do this it must first be realized, from reference to the above work on gates, that each + sign implies an input to an OR gate, and each "product" requires inputs to an AND gate, e.g. the sum $AB + C$ requires an AND gate with 2 inputs and an OR gate with 2 inputs, one of which will be the output of the AND gate. Returning to the above example where the circuit equation is $F = \bar{A}B + A\bar{B}$. There are two products, therefore two, two-input AND gates are required. There is one OR gate which has two inputs which are the outputs of

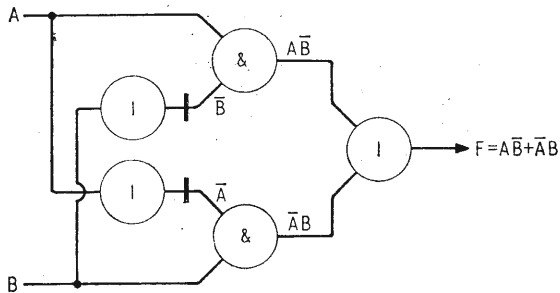

Fig. 12

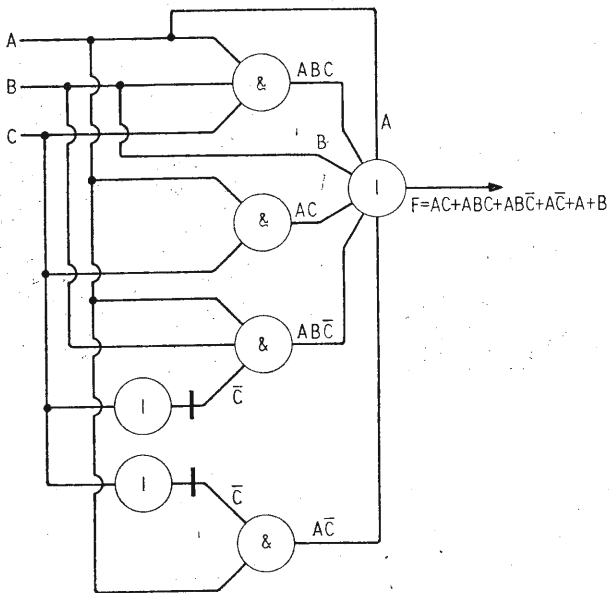

Fig. 13

the AND gates. In addition two NOT circuits are required for \bar{A} and \bar{B} (see Fig. 12).

In practice we shall encounter more complex expressions such as $F = AC + ABC + AB\bar{C} + AC\bar{C}$; the diagram for this may be drawn directly, as in Fig. 13.

Although two inverters for \bar{C} are shown, one would serve to drive both inputs.

This is a good example to which we can apply some of the rules which were stated above. The first step is to factorize the equation where possible, i.e.

$$\begin{aligned}
 F &= A(C + \bar{C}) + AB(C + \bar{C}) + A + B \\
 \therefore &= A + AB + A + B = A + AB + B \text{ since } A + A = A \\
 \therefore &= A + B \text{ since } A + AB = A \qquad C + \bar{C} = 1
 \end{aligned}$$

Thus the rather complex circuit above may be replaced by one OR gate:—

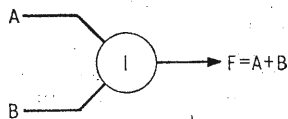

Electronic Circuits for Realization of Logical Operations

The next consideration is the realization of the logical functions AND and OR as electronic circuits. There are various types of electronic circuits which can be used to

perform these operations, of these, the simplest and cheapest is diode logic, examples of which are shown in Figs. 14 and 15.

Both gates, as shown, are for use with logic voltage levels of $-E$ volts \equiv "1" and 0 volts \equiv "0." Clearly in the case of the AND circuit, if either of the inputs A, B, or C are at 0 volts the output will be 0 volts, since one of the diodes D1-3 will be forward biased. (The output will actually differ from zero by the forward volt-drop of the diode, typically 0.3 volts.)

If A, B and C are simultaneously at $-E$ volts then the output will be $-E$ volts. If the inputs are all at different, (but negative) voltages, the output will not be greater than the lowest input voltage.

In the case of the OR gate, with all the inputs at 0 volts, the output will be approx. 0 volts. If A or B or C or any combination are at $-E$ volts the output will be $-E$ volts.

It is worth noting here that if the alternative convention of $-Ev \equiv$ "0" and $0v \equiv$ "1" is used it is simply necessary to interchange Figs. 14 and 15 to obtain the OR and AND functions respectively.

With this system the input sources must be able to supply current of the same order as the load current, and the output level is dependent upon the input conditions (i.e. no. of inputs in use and voltage levels). Signal levels deteriorate over a few stages and it is necessary to restore them by means of an amplifier stage (e.g. an emitter follower).

The common-emitter amplifier is used to perform the NOT function, Fig. 16.

When the input is at 0 volts ("0") the base of Vt1 is held positive by the potential divider R_1 and R_2 , cutting off Vt1. The output voltage is therefore $-E$ volts [neglecting volt-drop in R_3 due to transistor leakage current and assuming the circuit is unloaded]. The output is thus logic "1".

If the input changes to the "1" level, i.e., $-E$ volts,

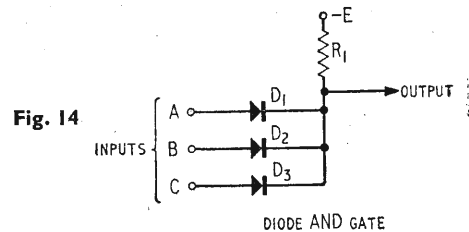

Fig. 14

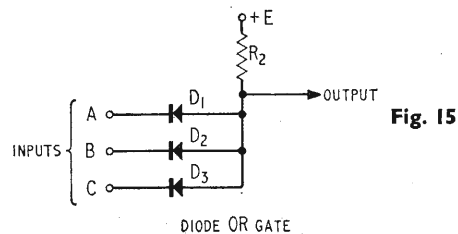

Fig. 15

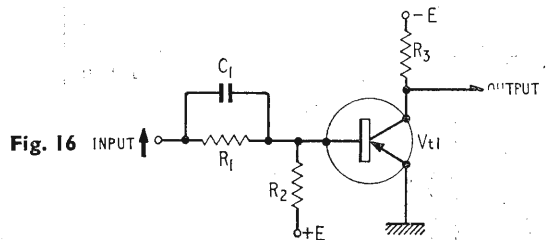

Fig. 16

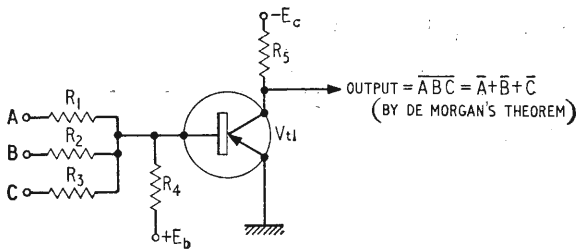

Fig. 17.

the base of Vt1 goes negative and Vt1 saturates. The volt-drop across R₃ is then approx. - E volts and the output is 0 volts (logic "0").

The above circuits lend very well to the design of standard circuits (or "logic building bricks") for logic systems. Rules can be evolved from which the allowable electrical interconnections may be determined. This reduces the design problem to one of formulating the equations, determining the best (irredundant) form, drawing the logic diagram and implementing a few rules. Such systems are commercially available.

Another system, which is also commercially available, and is gaining popularity, is the NAND/NOR system (otherwise referred to as Sheffer stroke Logic—Ref. 3). In this system the functions of NOT and AND are combined to give the NAND operation; similarly the NOT and OR to give NOR.

The basic circuit for NAND, using logic levels of 1 ≡ 0 volts and 0 ≡ - E volts, is illustrated in Fig. 17.

The base resistors R₁, R₂, R₃ are so chosen that with all inputs at 0 volts (1) Vt1 is cut off, and the output is approx. - E (0). If one or more inputs are at - E volts (0), Vt1 saturates and the output is 0 volts (1). The operation is the same as the inverter previously described but with an AND function at its input. Thus the equivalent circuit is:

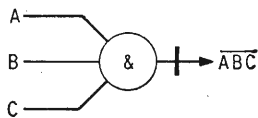

A convenient symbol is:—

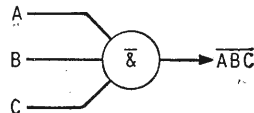

Clearly in the above circuit if the logic levels are interchanged, i.e., 1 = - EV and 0 = 0 volts, the transistor will conduct if either of its inputs are at "1" level and will be cut-off only when all its inputs are at the "0" level. This is then a NOR circuit, see Fig. 18. Since the circuits are duals it follows that one type may be used to perform all logical functions.

These circuits may also be designed as a "building brick" and have the advantage that amplification is available at each gate. This means that any one gate

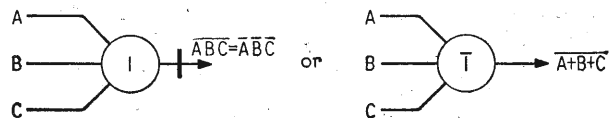
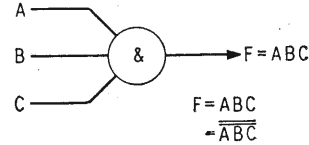

Fig. 18.

can drive a larger number of other gates than would be possible with a simple diode gate. An additional advantage is that the logic levels are restored to their correct values at each gate output, which can facilitate in fault-finding.

There are two approaches to the implementation of NAND logic. The first is simply to derive the logic diagram using Boolean algebra and then replace each element with its equivalent in NAND logic, e.g., for the simple AND gate shown:—



the equivalent NAND circuit is:—

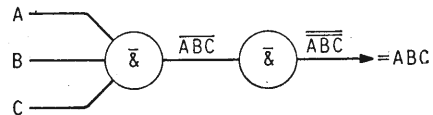

In this case we make use of the fact that $\overline{\overline{A}} = A$. We know that a single NAND gate produces complementation, so a second NAND stage is necessary.

Similarly for the OR function:—

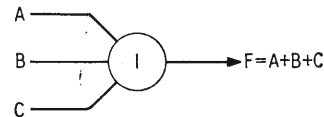

here we make use of De Morgan's theorem:—

$$F = A + B + C$$

$$= \overline{\overline{A} \overline{B} \overline{C}} = \overline{\overline{A} + \overline{B} + \overline{C}} = A + B + C$$

The extreme right-hand side is the required output, and the left-hand side may be interpreted as a three-input NAND gate whose inputs are \overline{A} , \overline{B} and \overline{C} , see Fig. 19.

From the above it is evident that to implement any one isolated function requires more elements than are used

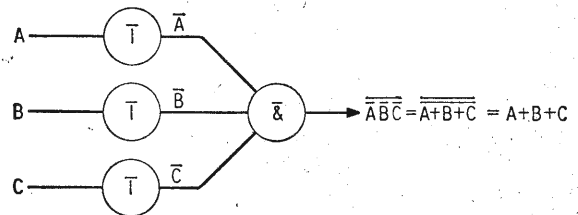

Fig. 19.

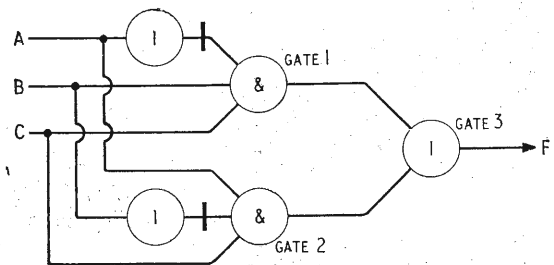

Fig. 20.

Fig. 22.

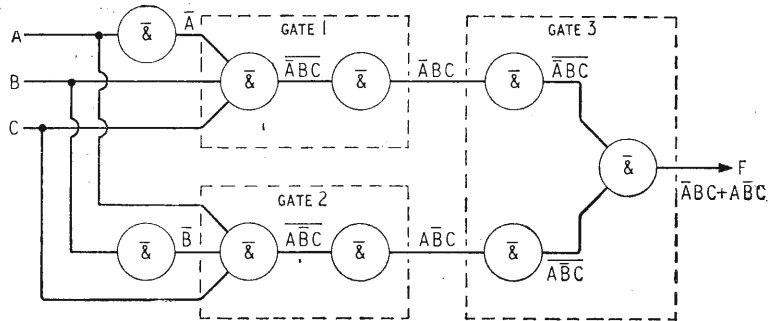
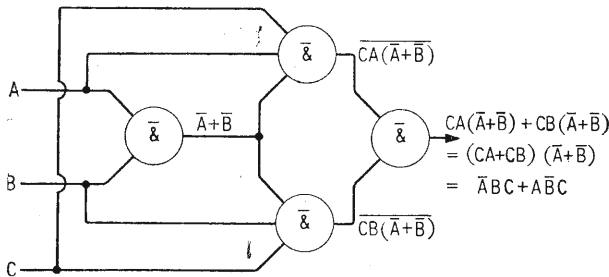

Fig. 21.



with the pure logic described earlier. However, in a larger system involving a combination of AND, OR and NOT functions, many elements may become redundant. This is shown in the following example.

Consider the function $\bar{A}BC + A\bar{B}C$. In pure logic this involves two AND gates (for the two products), two NOT elements and one OR gate, as shown in Fig. 20.

Fig. 21 shows the circuit using the NAND equivalents derived above.

Clearly the four gates which are crossed through are redundant since they merely perform a NOT operation twice on the same function.

The alternative approach to the design of this circuit is to rearrange the Boolean expression into a form which represents directly the outputs of NAND (NOR) elements. In the above case we can write:—

$\bar{A}BC + A\bar{B}C = \overline{ABC + A\bar{B}C}$, i.e., simply complementing each term twice.

Then by De Morgan's theorem

$$= \overline{A + B + C + A + B + C}$$

Each term and the entire expression now represents the output of a NAND element. Note that A must be complemented in the first term and B in the second term.

The resulting circuit is seen to be identical to that obtained above by the "equivalent circuit" method. This is not, however, the most economical solution. This may be found by applying the theorems developed above, e.g.,

$$\begin{aligned} \bar{A}BC + A\bar{B}C &= C[\bar{A}B + A\bar{B}]. \text{ By the Distributive AND rule.} \\ &= C[\bar{A}B + A][\bar{A}B + A\bar{B}] \text{ By the Distributive OR rule.} \\ &= C[(A+B)(A+\bar{A})(\bar{A}+\bar{B})(B+\bar{B})] \\ &\text{By the above rule,} \\ &= C[(A+B)(\bar{A}+\bar{B})] \\ &= CA(\bar{A} + \bar{B}) + CB(\bar{A} + \bar{B}) \end{aligned}$$

In the last step we have a common factor $\bar{A} + \bar{B}$, i.e., a single NAND element with inputs A and B. The complete circuit is shown in Fig. 22.

The above example serves to illustrate how NAND

(NOR) logic may be implemented using the methods of Boolean algebra. The final circuit uses four elements, i.e., four transistors, compared with the original circuit using AND/OR logic which required 3 gates and 2 inverters, a total of 8 diodes and 2 transistors. Since the cost of diodes and transistors are of the same order and the NAND circuit has greater driving power, the advantages of using this latter type of logic is obvious.

It is not proposed to pursue these topics further or to consider sequential switching circuits which are beyond the scope of the present article. It is hoped that the original aim to provide an introduction to "the algebra of switching circuits" has been served. A more detailed treatment of the subject may be obtained from Refs. 2 and 3 below.

Finally, I would like to acknowledge the help and encouragement of my colleagues in the preparation of this article and the permission of the Engineer-in-Chief G.P.O., for permission to publish.

REFERENCES

1. "An Investigation into the Laws of Thought." G. Boole, 1854.
2. The Logic Design of Transistor Digital Computers. Maley & Earle. (Prentice-Hall.)
3. "A Set of Five Independent Postulates for Boolean Algebra", H. M. Sheffer, Trans. Amer. Math. Soc. Vol. 14. (1913.)
4. "Switching Circuits for Engineers." M. P. Marcus, (Prentice-Hall) (1962).

U.K. Stereo Broadcasting

IN its annual report the B.B.C. states that it "believes that stereophony can produce a worthwhile improvement in reproduction, especially of music, and that there is a public demand for it, which though a minority demand is nevertheless substantial." It adds that stereo broadcasting would encourage v.h.f. listening, provide a new market for receivers and probably assist the radio industry in its export drive. However, no definite plans can be made to introduce a service until a decision is reached on the system to be used.

Until the adoption of a common system for use in Europe has been agreed upon all European countries introducing experimental stereo transmissions have been asked to use the pilot-tone or Zenith-GE, system.

The B.B.C.'s dual-transmitter stereo experiments on alternate Saturday mornings have been brought to an end. However, the experimental stereo transmissions from the London v.h.f. station at Wrotham on 91.3 Mc/s using the pilot-tone system will be continued. These are now being radiated on Tuesdays, Wednesdays and Thursdays from 2.30-3.00 (test tone) and 3.15-3.45 (programme material).

The recently licensed commercial radio station in Douglas, Isle of Man, now transmits a regular stereo programme. It uses two frequencies in the v.h.f. band as well as m.w.

COMMERCIAL LITERATURE

The November 1964 edition of the **Mullard Semiconductor Designers Guide** is now available from the technical office of the Industrial Markets Division of Mullard Ltd., Mullard House, Torrington Place, London, W.C.1. This 25-page publication begins with "Quick find transistor charts" that list the devices under the main headings of collector voltage, total dissipation and cut-off frequency, and is followed by a "Quick alphabetical/numerical guide" that describes the devices from type numbers. A Mullard C.V. list precedes the main body of the publication, which deals more fully with the technical details of their semiconductors. International outlines, to which these devices comply are included in this booklet.

16WW 326 for further details

STC Semiconductor Devices Data Summary is the title of a new publication (No. M/106) available from the Components Marketing Division of Standard Telephones and Cables Ltd., which is based at Footscray, Sidcup, Kent. This publication lists the S.T.C. semiconductors currently in production (except thermistors—summarized in publication MK/140—and selenium rectifiers) and gives their essential ratings and characteristics. Outline drawings of the units are included and appear with a cross-reference to international standards to which they conform. Integrated circuits and other multiple devices are also featured in this 46-page booklet.

16WW 327 for further details

The 1964 edition of the **Kelvin Hughes** miniature general catalogue (48-pages) is now available from the publicity department, New North Road, Hainault, Ilford, Essex. This publication, the text of which is presented in English, French, German, Norwegian and Spanish, covers their radar, navigational instruments and fishing aids.

16WW 328 for further details

Variations of Muirhead's range of **precision wire-wound resistors** are given in a new 23-page publication entitled "Precision Resistors," available from Muirhead & Co., of Beckenham, Kent. A considerable amount of space is devoted to the selection of the resistors included, whose accuracies range from 1% to 0.02%, power ratings from 0.5 to 2 watts, and temperature coefficients down to 10 parts in 10⁶ per degree Centigrade.

16WW 329 for further details

Home Radio (Mitcham) Ltd., of 187 London Road, Mitcham, Surrey, announce the publication of their latest catalogue. Within its 200 pages, many hundreds of components, for which they act as stockists, are listed. These range from aerial sockets and b.f.o. coils to wire cutters and zener diodes. A comprehensive selection of audio equipment, communications receivers and measuring instruments is also included in the catalogue, for which a charge of 5s is made; recoverable through orders at a rate of 1s in the pound.

The **M.E.L. Equipment Company** has recently launched a house organ called *M.E.L. Review*. It gives brief details of new items from the development and production side of M.E.L. and its overseas associates. Further issues will be published at three to four month intervals. Applications for inclusion on the mailing list should be sent to the M.E.L. Equipment Co., 207 Kings Cross Road, London, W.C.1.

16WW 330 for further details

An abridged catalogue describing **new microwave instruments** has been forwarded to us by the Radar and Communication Instruments Division of Elliott Brothers (London) Ltd., of Elstree Way, Boreham Wood, Herts. In addition to instruments, it gives details of a number of accessories including X- and Q-band crystal detector mounts, attenuators, matched terminations and couplers, and an X-band waveguide to coaxial transformer.

16WW 331 for further details

Coaxial cables manufactured by **British Insulated Callender's Cables Ltd.**, and associated connectors and terminations made by **B.I.C.C.-Burdny Ltd.** are featured in a 32-page publication entitled **Radio Frequency Cables**. Section 1 of the publication (No. M.941B) deals with numerous types of coaxial cables and tabulates their electrical and physical characteristics. The second section of the publication, which is available from B.I.C.C.'s head office at 21 Bloomsbury Street, London, W.C.1, is sub-divided to cover r.f. connectors, Uniring and Hying terminations for coaxial cables, multiway connectors and installation tools.

16WW 332 for further details

"**The big difference is inside**" is the title of a recent leaflet from Tektronix U.K. Ltd., of Beaverton House, Station Approach, Harpenden, Herts. It describes the Mark B version of the Model 545 d.c. to 30 Mc/s oscilloscope, which has a similar electrical specification to the "A," but incorporates a number of circuit changes.

16WW 333 for further details

Possible applications of the **Type 8 closed-circuit television camera** are listed in a new brochure now available from EMI Electronics Ltd., of Hayes, Middx. Details are also given of the accessories which enable an elaborate network of cameras and receivers to be built.

16WW 334 for further details

Reprints from *Siemens-Review* of an article on "**High-Current Silicon Mesa Switching Transistors**" by Günther Eberhard are now available from R. H. Cole Electronics Ltd., of 7-15 Lansdowne Road, Croydon, Surrey. The article is based on the Types BUY 12 and BUY 13 transistors developed by Siemens & Halske.

16WW 335 for further details

Zonal Film (Magnetic Coatings) Ltd., of 23 Roden Street, Ilford, Essex, have just published a 12-page booklet entitled **The Basis of Every Good Magnetic Recording**. It comprises two sections, the first of which gives a brief description of the grades of Zonatape available, and how a top quality recording is made and tested. Suggestions from a professional recordist appear in the latter part on how to get the best from tape recordings and from tape recorders.

16WW 336 for further details

Three technical publications issued during September by the Westinghouse Brake and Signal Company, of 82 York Way, King's Cross, London, N.1, deal with **silicon power transistors**. The first of these (36-100) describes the Types 151 and 152 transistors which have a power dissipation of 100 watts and are available with collector-to-emitter characteristics of 80 to 200 volts maximum. Technical Publication 36-101 deals with Types 153 and 154 which have twice the power rating of the 151 and 152 and versions are available with maximum collector-to-emitter voltages from 65 to 225V. The other publication (36-104) covers the Types 163 and 164 which are similar to the 153 and the 154, but are able to pass 20 A. as against 7.5 A. The Types 151 and 152 are rated at 6A. Copies are available from the Rectifier Division.

16WW 337 for further details

A leaflet describing the Elremeco "**Crystal**" **auto-reset dial timer** is now available (List No. 200) from the Electrical Remote Control Company of Bush Fair, Harlow, Essex. A mechanical and electrical specification of the timer, which is driven by a non-reversing synchronous motor, is included along with mounting instructions. Standard time ranges are from 0-10 seconds up to 0-48 hours.

16WW 338 for further details

Stereo Record Care.—Cecil E. Watts, a pioneer of disc recording, gives sound advice in a 16-page booklet "A Guide to the Better Care of Your L.P. and Stereo Records," obtainable from him at Darby House, Sunbury-on-Thames, Middx., price 6d by post.

"CHORUS"

By MICHAEL LORANT

RESULTS OF RECENT INVESTIGATIONS INTO ONE TYPE OF WHISTLER ATMOSPHERIC

ORIGINALLY named "dawn chorus" for its resemblance to sounds of birds in the English countryside at dawn, "Chorus," as it is now generally named, consists of a multitude of tones rising in frequency from 1 to 2 kc/s and usually lasting 0.1 to 0.5 second. It is often accompanied by noises or hiss, covering the same frequency as those contained in the chorus. Often it will occur in bursts, starting from a background of little or no chorus, rapidly building up in intensity and repetition rate, and then receding to background noise.

No adequate theory of the origin of Chorus is accepted, although several hypotheses have been proposed by researchers. The best known is the travelling-wave hypothesis; others include plasma oscillations in the exosphere, Cerenkov radiation, and radiation from protons spiralling down the field lines with gyromagnetic frequency Doppler-shifted by an amount depending on the velocity of the particles and the ambient electron density. This last hypothesis is supported by results obtained by Murcray and Pope.

Receiving Equipment

Since Chorus is an e.l.f./v.l.f. emission it can be received on equipment for listening to "whistlers," another v.l.f. phenomenon. This has made many stations readily available for chorus observations. The equipment used consists of an aerial, an amplifier having a voltage gain of about 10^6 and a passband from 500 c/s to 15 kc/s, and a tape recorder. The aerial used at the College, Alaska station, for example, is a delta-shaped loop antenna 30 feet high and 60 feet across the base.

Chorus activity is sampled at each participating station by recording it on magnetic tape for 2 minutes of each

hour, beginning at 35 minutes past the hour. The strength of each Chorus sample is evaluated as an integer on a 0-5 scale by monitoring technicians, each of whom is specially selected on the basis of his audio responses.

Influence of Latitude

Observations recorded at 29 whistler stations were used in the Bureau's study. Three of the stations (College, Kotzebue, and Barrow) were operated by the Geophysical Institute of the University of Alaska. The rest were scattered over the western hemisphere and Europe, from Alaska to Antarctica, and from Sweden westward to Australia. Observations were made of Chorus at the College, Alaska station from 1956 to the present time, and at each of the other stations for several years.

The occurrence of Chorus is greatest in the region between 60° and 70° geomagnetic latitude in both hemispheres. While experimental scatter prevents more accurate determination of this region, the correspondence with the auroral zones seems significant.

Chorus activity shows seasonal variations at all stations, but not in the same pattern for all; some stations exhibit maxima during winter and others during summer. However, Chorus activity does seem to reach its peak during summer at stations at low latitudes and in winter at high latitudes, although additional evidence is needed to render this finding conclusive.

All stations examined show a definite diurnal variation and, as has been known for some time, a time of diurnal maximum related to the latitude of the station. Above the zone of auroral maximum, however, this

Fig. 1. Data used in the U.S. National Bureau of Standards' study of "Chorus" originated from the world-wide array of whistler-study stations shown in this map. Many of the data were obtained during participation of these stations in the IGY programme. Continuous data were provided by the College, Alaska station (CO), one of the three operated by Geophysical Institute of the University of Alaska.

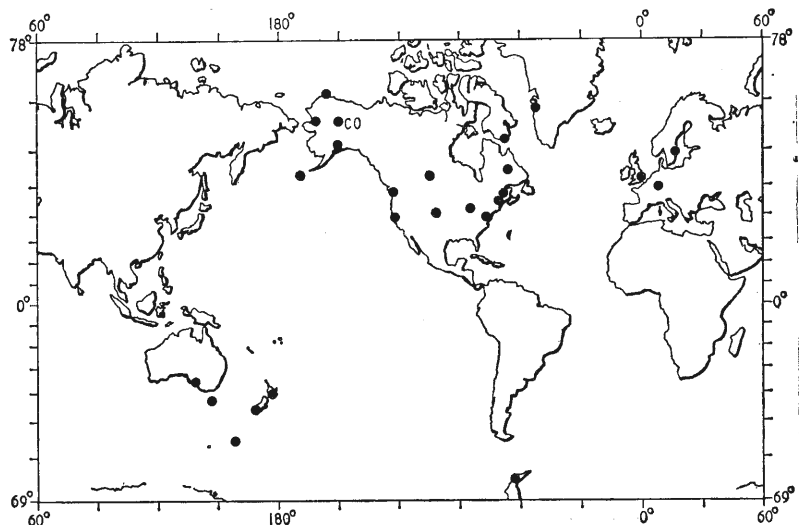

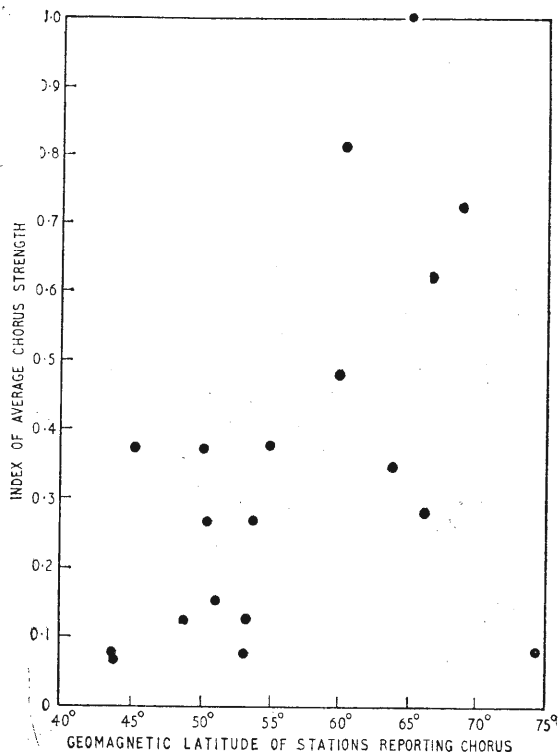

Fig. 2. The average index of "Chorus" was greatest at stations between latitudes 60° and 70°, North and South. Stations reporting indexes above 0.5 are those located at College, Alaska; Macquarie Island (near Antarctica); Barrow, Alaska and Ellsworth, Antarctica.

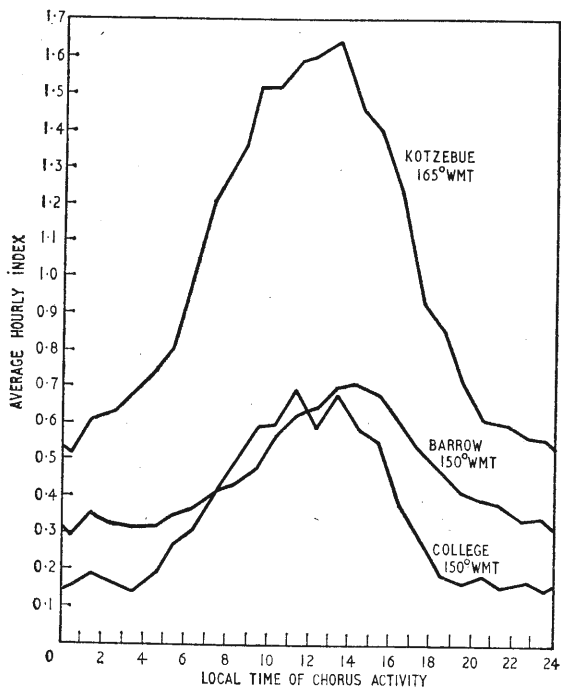

Fig. 3. Plots of the hourly average index of chorus activity are similar in shape for three different Alaskan stations, although greatly different in level.

dependence breaks down. A pronounced delay in diurnal peak with increasing geomagnetic latitude is evident.

Chorus is found to be related to geomagnetism, having a positive correlation index in the lower latitudes of 0.5 to 0.6 with the geomagnetic K-indices (an approximate measure of solar-terrestrial particle activity as determined from magnetograms). At the high latitudes, however, the correlation varies with the season in a complex way, being positive near the solstices and negative near equinoxes.

Frequency Patterns

Chorus varies greatly in its frequency—the tone may either ascend or descend, or even consist of simultaneously ascending and descending branches. It may warble or be relatively steady. Statistical studies of Chorus frequencies can be made using the highest frequency, the lowest frequency, the mid-frequency, and the rate of change of frequency. An earlier study at the College, Alaska station showed that the mid-frequency varies diurnally. The maximum frequency was used in the studies to avoid the greater influence of harmonics of powerline noise on measurements of minimum frequency and mid-frequency.

Plots of variation of maximum frequency against season and hour of day at the Barrow, College, and Kotzebue Alaskan stations show a marked similarity. Not only are maximum frequency patterns similar for the three stations for the measured years, but the plots of average maximum frequency during a day were similar for the three Alaskan stations, each approaching a marked diurnal peak in the evening hours before midnight. Further analysis of the rate of Chorus frequency changes observed at the three stations showed a surprising similarity, both among stations and for different years.

REFERENCES

- "A high-latitude investigation of the natural very-low-frequency electromagnetic radiation known as Chorus," by J. H. Pope, *J. Geophys. Res.* **68**, 83-99 (Jan. 1, 1963).
- "Origin of very-low-frequency emissions," by R. M. Gallet and R. A. Helliwell, *J. Res. NBS* **63D**, 21-27 (July 1959).
- "The very-low-frequency emission generated in the earth's exosphere," by R. M. Gallet, *Proc. I.R.E.* **47**, 211-231 (Feb. 1959).
- "A study of the audio-frequency radio phenomenon known as 'dawn chorus,'" by M. McK. Allcock, *Aust. J. Phys.* **10**, 286-298 (June 1957).
- "Physics of the Aurora and Airglow," by J. J. W. Chamberlain, p. 278, Academic Press, New York (1961).
- "Theory of the origin of the very-low-frequency radio emissions from the earth's exosphere," by J. W. MacArthur, *Phys. Rev. Letters* **2**, 491-492 (June 1959).
- "Doppler shifted cyclotron frequency radiation from protons in the exosphere," by W. B. Murcray and J. H. Pope, *Phys. Rev. Letters* **4**, 5-6 (Jan. 1960).
- "Radiation from protons of auroral energy in the vicinity of the earth," by W. B. Murcray and J. H. Pope, *J. Geophys. Res.* **65**, 3569-3574 (Nov. 1960).
- "Energy fluxes from the cyclotron radiation model of v.l.f. radio emission," by W. B. Murcray and J. H. Pope, *Proc. I.R.E.* **49**, 811-812 (April 1961).
- "The eccentric geomagnetic dipole," by W. D. Parkinson and J. Cleary, *J. Geophys.* **1**, 346 (Dec. 1958).
- "An investigation of whistlers and Chorus at high latitudes," by J. H. Pope, Sci. Report 4 AF 19 (604)-1859, U. of Alaska (1959).

JANUARY MEETINGS

Tickets are required for some meetings: readers are advised, therefore, to communicate with the secretary of the society concerned

LONDON

4th. I.E.E.—“The present state of gallium arsenide technology” by J. R. Knight and K. Hambleton at 5.30 at Savoy Place, W.C.2.

11th. I.E.E.—“Speech compression” by Dr. J. Swaffield at 5.30 at Savoy Place, W.C.2.

13th. I.E.E. & I.E.R.E.—“Potential levels in the central nervous system—their detection and significance” by Prof. Sir Bryan Matthews at 5.30 at Savoy Place, W.C.2.

14th. S.E.R.T.—“Transistorized hi-fi” by D. M. Chave at 7.15 at the London School of Hygiene and Tropical Medicine, Keppel Street, W.C.1.

20th. I.E.R.E.—“Acoustic communication underwater” by Dr. B. K. Gazey and Dr. J. C. Morris at 6.0 at London School of Hygiene and Tropical Medicine, Gower St., W.C.1.

20th. Soc. of Environmental Engrs.—“A central recording station for a climatic laboratory” by R. T. Lovelock at 6.0 at the Mechanical Engineering Dept., Imperial College, Exhibition Rd., S.W.7.

21st. I.Mech.E.—Discussion on “Information retrieval” at 4.0 at 1 Birdcage Walk, S.W.1.

22nd. I.E.E. & I.E.R.E.—Discussion on “The direct recording of biological signals” at 2.30 at Savoy Place, W.C.2.

22nd. I.E.E.—Colloquium on “Network analysis” at 2.30 at Savoy Place, W.C.2.

22nd. Instn. of Electronics.—“The high-quality reproduction of sound” by K. F. Russell at 6.45 at Senate Hall, University of London, Maddox St., W.C.2.

25th.—I.E.E. & I.E.R.E.—Colloquium on “Logic circuits” at 10.30 a.m. at Savoy Place, W.C.2.

26th. I.E.E.—Colloquium on “Analogue to digital conversion” at 3.0 at Savoy Place, W.C.2.

26th. Royal Society of Arts.—“The British contribution to educational television in the Commonwealth” by L. J. Lawler at 5.15 at John Adam Street, W.C.2.

27th. I.E.R.E.—Symposium of short papers on “Enhancement and absorption of radar radiation” at 6.0 at London School of Hygiene and Tropical Medicine, Gower Street, W.C.1.

28th. Inst. of Phys. & Phys. Soc.—“Listening and acoustical measurements in recent concert halls” by Dr. Leo L. Beranek and “Some experiences with recently opened concert halls in Germany,” by Dr. H. Kuttruff at 3.0 in the Physics Dept., Imperial College, Prince Consort Rd., S.W.7.

ABERDEEN

13th. I.E.E.—“The planning of communication satellite systems” by F. J. D. Taylor and J. K. S. Jowett at 7.30 at Robert Gordon's Technical College.

BIRMINGHAM

4th. I.E.E.—Discussion on “The changing pattern of technological education and training” at 6.15 at the College of Advanced Technology, Gosta Green.

19th. I.E.E.—Faraday Lecture on “Colour television” by F. C. McLean at 7.0 at the Town Hall.

20th. Television Soc.—“Television facilities—1: Live, tape or film?” by I. Atkins at 7.0 at the College of Advanced Technology, Gosta Green.

BRIGHTON

19th. I.E.R.E.—“Design and applications of a fast industrial static switching system” by G. W. Pontin at 6.30 at the College of Technology.

BRISTOL

20th. I.E.R.E. & I.E.E.—“Some aspects of radio-active particle detection techniques and associated circuit design” by J. R. Brown at 7.0 at the University Engineering Laboratories.

CARDIFF

13th. I.E.R.E. & I.E.E.—“Parametric amplifiers” by Dr. T. Buckley at 6.30 at Welsh College of Advanced Technology.

CHELTENHAM

29th. I.E.R.E.—“Digital storage” by W. Renwick at 7.0 at North Gloucestershire Technical College.

DONCASTER

19th. I.E.E.—“Motor control using silicon controlled rectifiers” by N. J. Duncan at 6.30 at the Technical College, Waterdale.

DUNDEE

14th. I.E.E.—“The planning of communication satellite systems” by F. J. D. Taylor and J. K. S. Jowett at 7.0 at the Electrical Engineering Dept., Queen's College.

EDINBURGH

12th. I.E.E.—“Digital techniques for multiplying frequency” by A. Russell at 6.0 at the Carlton Hotel, North Bridge.

13th. I.E.R.E.—“Quality and reliability” by F. Baxter at 7.0 at The University, Drummond Street.

FARNBOROUGH

14th. I.E.R.E. & I.E.E.—“Attitude control of the Skylark sounding rocket” by J. F. M. Walker at 7.0 at the Technical College.

GLASGOW

11th. I.E.E.—“Digital techniques for multiplying frequency” by A. Russell at 6.0 at the University of Strathclyde, George Street.

14th. I.E.R.E.—“Quality and reliability” by F. Baxter at 7.0 at Institution of Engineers and Shipbuilders, 39 Elmbank Crescent.

LEEDS

26th. I.E.E.—Discussion on “The new H.N.C. in electrical and electronic engineering” opened by A. D. Collop at 6.30 at Leeds College of Technology.

LEICESTER

19th. Television Soc.—“Medium screen colour projection” by P. Lowry at 7.15 at the Vaughan College, St. Nicholas Street.

21st. I.E.E.—Faraday Lecture on “Colour television” by F. C. McLean at 7.15 at the De Montfort Hall.

LIVERPOOL

20th. I.E.R.E.—“Radio astronomy” by Dr. R. C. Jennison at 7.30 at Walker Art Gallery.

25th. I.E.E.—Discussion on “Solid state concepts in teaching engineers” opened by J. H. Leck at 6.30 at the Royal Institution, Colquitt Street.

LOUGHBOROUGH

28th. I.E.R.E. & I.E.E.—“Nuclear instrumentation” by R. B. Quarmby at 6.30 at the College of Advanced Technology.

MALVERN

18th. I.E.E.—“Pulse compression radar” by H. H. Boyenval at 7.30 at the Winter Gardens.

MANCHESTER

7th. S.E.R.T.—“Solid state dielectrics” by R. I. Walker at 7.30 at the Engineers' Club, Albert Square.

12th. I.E.E.—“Inertial navigation” by R. Whalley at 6.15 at the Manchester College of Science and Technology.

18th. Inst. Eng'g. Inspection.—“Non-destructive testing by electronic instruments” at 7.45 at Manchester Literary and Philosophical Society, 36 George Street.

26th. I.E.E.—Faraday Lecture on “Colour television” by F. C. McLean at 2.15 and repeated at 7.30 at the Free Trade Hall.

NEWCASTLE UPON TYNE

13th. I.E.R.E.—“Field effect transistors and their applications” by C. S. den Brinker at 3.0 at Institute of Mining and Mechanical Engineers, Westgate Road.

OXFORD

13th. I.E.E.—“Modern telephone developments with particular reference to electronic techniques” by L. R. F. Harris at 7.0 in the Demonstration Room, S.E.B., 37 George Street.

PORTSMOUTH

20th. I.E.E.—“Small signal measurements in nuclear electronics” by G. D. Smith at 6.30 at the College of Technology, Anglesea Road.

READING

25th. I.E.E.—“Planning for the new TV services” by R. A. Dilworth at 7.30 at the Great Western Hotel.

SOUTHAMPTON

12th. I.E.E.—Discussion on “Field effect devices” opened by Dr. R. E. Hayes at 6.30 at the University.

23rd. Instn. of Electronics.—“The high-quality reproduction of sound” by K. F. Russell at 2.0 at Nuffield Theatre, University of Southampton, Highfield.

WOLVERHAMPTON

20th. I.E.R.E.—“Microelectronics” by Dr. J. W. Granville at 7.15 at Wolverhampton College of Technology.

NEWS FROM INDUSTRY

Domestic Manufacturers' Despatches.

—According to estimates issued by the British Radio Equipment Manufacturers' Association, the number of television sets despatched to the home market in the first nine months of last year totalled 1,280,000. This represents an increase of 205,000 on the same period of 1963 and 424,000 more than in the same period of 1962. Sound receiver despatches (including car radio) for the first nine months of 1964 totalled 1,710,000; 14% down on the corresponding period of 1963 and 11% less than the 1962 figure. Radiogram despatches to September totalled 184,000; exceeding the 1963 figure by 13% and the 1962 figure by 59%. Incidentally, these figures include sets sent to rental and relay companies.

The gross profit, before providing for depreciation of rental assets and for taxation, of **Robinson Rentals (Holdings) Ltd.** for the year ended 30th September, 1964, amounted to £2,315,906 compared with £1,909,841 for the previous financial year. Provision for depreciation of rental assets took £1,554,090 (£1,234,306) and taxation £208,261 (£250,615), leaving a net profit of £553,555 (£424,920).

Mazda and Brimar Application for R.P.M.—Thorn-AEI Radio Valves Tubes Ltd. have made application under the Resale Prices Act of 1964 for exemption from price decontrol for all of their valves, tubes and semiconductors marketed under the brand names Mazda and Brimar. The company also announces that their Scottish service depot, which handles dealers' claims on cathode ray tubes, has moved from 151 North Street to 517 Lawmoor Street, Glasgow, C.5. (Tel.: Glasgow SOUTH 5151.)

Orders worth nearly £1,000,000 have been placed by the Ministry of Defence for **Marconi self-tuning transmitting equipment.** This equipment is to be used by the Admiralty to modernize and expand parts of its world-wide h.f. communications network. Twenty-five 30 kW transmitters, special frequency generating equipment and a large number of drive channels incorporating transistor frequency synthesizers are to be supplied under these orders.

Owing to the increased demand for **Mullard transistors**, which are manufactured by the jointly owned Mullard-G.E.C. company Associated Semiconductor Manufacturers Ltd. (whose main plant is at Southampton), a semiconductor production line is to be set up at the Blackburn plant of Mullard Ltd. This will in no way affect the production of valves at the Blackburn plant, which is still at a high level and is expected to remain so for some years. Other recent extensions of the Mullard organization include expansion at the valve factory at Haydock in Lancashire, to allow the present staff of 300 to be increased to 400 in the next few months. This factory is one of six "feeders" carrying out assembly work on radio and television valves for the parent plant at Blackburn. The extension involves 26,500 sq ft.

The **Marconi Company** announces that a **Microelectronics Division** has been formed at Baddow, Essex, to exploit the techniques that have resulted from the company's research investment in this field. Mr. I. G. Cressell, former chief of the company's semiconductor physics group at Baddow, is the division's new manager.

A new division, known as the **Transmission Supplies Division**, has been established at Standard Telephones and Cables' new factory at East Kilbride in Scotland. This division will be responsible for making the mechanical parts for long-distance telephone, television and teleprinter transmission equipment. A substantial part of the division's job will be the manufacture of waveguide components.

Short-term leasing of scientific instruments and equipment is the primary function of the newly formed company **Scientific Rentals Ltd.**, of 84 Lower Mortlake Road, Richmond, Surrey. (Tel.: RICHmond 5656.) The company's directors are P. Goudime and K. B. Hogg.

Osmor Radio Products Ltd. have moved from their Crunden Road works in Croydon to new premises at 540 Purley Way, Croydon, Surrey. Their telephone number Croydon 5148 remains unchanged. The new factory covers an area of 65,000 sq ft and incorporates a new impregnation plant.

From overseas

Australia

Qantas, one of Australia's largest airlines, have decided to fit **Marconi Doppler navigation equipment** in their fleet of Boeing 707 aircraft operating the trans-Pacific route.

A number of **v.h.f. transistor radio-telephones** made by the Automatic Telephone and Electric Company are being used to link remote out-stations into Australia's telephone network. With these battery-operated units, subscribers

use conventional telephone installations, that allow them to dial directly into the system.

Belgium

The capacity of an existing **underwater telephone cable**, linking the United Kingdom with Belgium, and its associated terminal equipment has recently been increased from 216 to 420 telephone circuits. This was carried out by Submarine Cables Ltd. and involved cutting the cable in two places, to insert transistor repeaters, and replacing the valve terminal equipment with transistor apparatus.

Canada

Through its Canadian subsidiary, the English Electric Valve Company have received an order from Lenkurt Electric, of North America, for a number of **travelling-wave tubes** and associated mounts. Lenkurt Electric have an order from Alberta Government Telephones to build a radiotelephone system, containing 21 intermediate stations, between Lethbridge and Peace River.

The Canadian Westinghouse Company are to supply an accurate **aerial position sensor and error generator** for the closed-loop servo systems of an 85-ft dish aerial being built at the experimental communications ground station in Nova Scotia by the Department of Transport. The RCA Victor Company are main contractors for this project.

Germany

The first **aircraft-noise monitor** to be used in Western Germany is now in operation at Frankfurt Airport. This equipment, which was developed by Rohde and Schwarz, automatically records the engine noise, heard in the surrounding residential areas, of aircraft landing and taking off. The installation comprises six fixed check points, a monitoring centre and a test van, and supplies the airport administration with a record of excess noise levels and their duration.

High performance **weather surveillance radar** from Decca has been installed in the University of Berlin by Telefunken A G and is now fully operational. Its coverage extends to Scandinavia and the Baltic in the north and to Austria in the south.

Hungary

An order, through Elektroimpex Budapest, has been placed by the Hungarian civil airline Malev for a Decca Type AR-1 multi-purpose **air surveillance radar.** It is the first of its kind to be exported to eastern Europe and is to be installed at the Budapest international airport, Ferihegy.

The Austrian company Wiener Siemens Werke, who supplied the equipment for linking the programme studios, recording studios and a number of other facilities for Radio Budapest, have just completed a **switching centre** that will enable Radio Budapest to transmit up to six programmes simultaneously.

Norway

The Norwegian Government is planning to set up five chains of **Decca Navigator stations** to cover the whole of the west coast of Norway, principally to help their fishing industry. The cost, including construction work, is estimated to be £2,500,000. Decca, of London, are to supply the electronic equipment for the transmitting stations and the marine Decca Navigator receivers are to be manufactured in Norway under licence.

U.S.A.

Radiation Incorporated, of Melbourne, Florida, announce that the aerial system they have developed for the U.S. Air Force is now installed on the Air Force tracking ship "Twin Falls Victory." This apparatus is being used to track and receive telemetry data from the Mariner C spacecraft, which is on its way to Mars. Sensitive converter/receivers are used in the front end of the aerial system to convert the received S-band data from the spacecraft to 300-400 Mc/s. Nine of these were supplied under the \$1M contract.

Two contracts for **telemetry transmitters** have been awarded to Eitel-McCullough Incorporated by the Los Angeles Navy Purchasing Office. One calls for a 2-watt unit for operation at 2.2 to 2.3 Gc/s and the other for a 2.5-watt unit at 1.435 to 1.535 Gc/s.

U.S.S.R.

Digital Measurements Ltd. have received an order for 27 **digital voltmeters** and associated spares from the Soviet Union. The value of this order is £20,400.

Agencies and agreements

Superior Electric Nederland N.V., a wholly owned subsidiary of the American **Superior Electric Company**, have appointed Spectrum Electronics Ltd., of Deneway House, Darkes Lane, Potters Bar, Middx., as U.K. distributors.

Livingston Laboratories Ltd., of 31 Camden Road, London, N.W.1, have been appointed sole British representatives for the industrial products of the X-Ray Department of the **American General Electric Company**.

Painton & Company, of Northampton, announce the formation of a German subsidiary company, **Painton G.m.b.H.** It will operate from Wuppertal-Elberfeld.

Existing **Ferranti representation in France** by Compagnie d'Equipments de Regulation Automatique et de Mesure, of Paris, is to be extended to include process control equipment.

Ketay Ltd., of Eastern Avenue West, Chadwell Heath, Romford, Essex, have reached an agreement with **Harowe Servo Controls Incorporated**, of Pennsylvania, whereby they become the sole distributors for the Harowe range of servo products in this country, Europe and the Commonwealth.



THE HOUSE OF BULGIN AT YOUR SERVICE

FOR UNFAILING QUALITY! ELECTRICAL EFFICIENCY! BULGIN FUSEHOLDERS

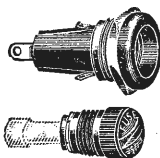

List Nos. F.296 and F.297.



List No. F.180.

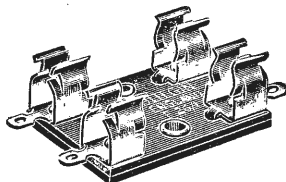

List Nos. F.26/3, F.26/2.

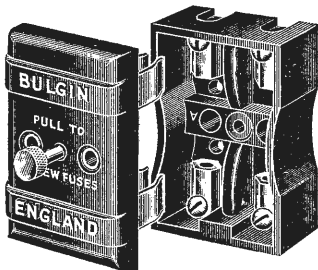

List No. F.119.

UNIQUE SINGLE-POLE NEON FUSEHOLDER

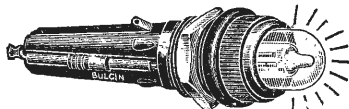

List No. D.F.826/V.
Patent Number 930330.
U.S.A. Patent Applied No.186/676.

Manufacturers of the largest range of Fuseholders of proven reliability for 5 mm. x 20 mm. — $\frac{3}{16}$ in. x $\frac{1}{2}$ in. — $\frac{1}{4}$ in. x $\frac{1}{2}$ in. — $\frac{1}{8}$ in. x $\frac{1}{2}$ in. — $1\frac{1}{2}$ in. x $\frac{1}{2}$ in. FUSES. Their reputation stands high in the estimation of critical engineers who have had utmost faith in them for many years.

- ★ OPEN TYPES
(SINGLE, DOUBLE & TRIPLE POLE)
- ★ MOULDED TYPES
(OPEN OR COVERED)
- ★ WIRED-IN-FLEX TYPES
(METAL OR MOULDED)
- ★ PANEL-MOUNTING TYPES
- ★ PRINTED CIRCUIT TYPES
- ★ BAYONET CAP TYPES
- ★ DELIVERY MOSTLY FROM STOCK

"WHEN IT BLOWS IT GLOWS"

Instant indication of blown fuses allowing quick replacement when used in multiples.

A. F. BULGIN & CO. LTD.,
Bye Pass Rd., Barking, Essex.
Tel: RIPpleway 5588 (12 lines)

MANUFACTURERS AND SUPPLIERS OF RADIO
AND ELECTRONIC COMPONENTS TO

ADMIRALTY	MINISTRY OF WORKS	B.B.C.
WAR OFFICE	MINISTRY OF AVIATION	G.P.O.
AIR MINISTRY	MINISTRY OF SUPPLY	I.T.A.
HOME OFFICE	RESEARCH ESTABLISHMENTS	N.F.L.
CROWN AGENTS	U.K.A.E.A.	D.S.I.R.

1WW-123 FOR FURTHER DETAILS.

The Great Electronics Myth

IN the December issue the Editor, no doubt inspired by a Scroogian spirit of anti-Christmas, put a particularly belligerent cat among some peculiarly inoffensive pigeons by calling for a fully embracing definition of the term "electronics."

At first thought the requirement hardly seems to exist. Everybody knows what electronics is. It's—er—well—it's anything to do with radio transmitters or receivers or television cameras or studio equipment in general, or record players or aerials or computers or hearing aids or—and so on through a very lengthy list. It is not until one searches for some sort of common denominator that the Editor's Machiavellian purpose begins to show.

You will have noticed that while he has drawn our attention to various definitions of electronics, he has been careful not to add one of his own. This, of course, is not because he has not got one, but because editors as a race run contrary to the precepts of King Solomon, digging pits into which they fall not and rolling stones which return not upon them. It is a gambit which is technically known as "stirring up the correspondence columns." And as this particular pit, stone or topic is one which is guaranteed to estrange brother from brother, husband from wife and Group Leader from Section Leader, I have no doubt that the P.M.G. is at this moment reaping a rich harvest of postal dues. Not until the spate of letters falls to a trickle will the Editor spring his own contribution and thereby put us mere electronics wage slaves to shame by its wisdom.*

But to the task. A definition. My dictionary tells me that electronics is "a branch of physics dealing with electrons and other elementary particles (protons, neutrons, etc.) that constitute matter." There is no mention of industry here, and just as well, too, for matter being what it is, every industry under the sun would qualify for an electronics label.

So let us turn to the British Standard definition, to wit:—"Electronics. That branch of science and technology which deals with a study of the phenomena of conduction of electricity in a vacuum, in a gas and in semiconductors, and with the utilization of devices based on these phenomena."

This on the face of it seems to answer all requirements out of hand. But does it, on sober reflection? For a start, its "conduction in a gas" clause seems to bring MHD generation into the field of electronics, so we are liable to find ourselves working for the C.E.G.B. any moment now.

Other Components

Again, it seems to me to be based on the dubious assumption that the valve or transistor is the all-important component in any given circuit. Certainly, no equipment would function without it, but then, neither would it if any of the other components were removed. Would you accept it as logical if the motor industry called itself the carburettor industry on the grounds that this was the key device in a petrol engine?

On a quick check over the circuit diagram of a typical domestic television receiver I find that it uses 156 resistors, 128 capacitors, 76 inductors, 17 miscellaneous devices, 18

valves and 7 semiconductor diodes. If my arithmetic is correct, this gives a total of 402 components, of which 377 are electrical and only 25 qualify as truly electronic. Add to the former the great number of point-to-point connections involved, and our so-called electronic equipment turns out to be a vast ocean of electrical engineering in which are disposed a few islets of electronics. Government by minority indeed!

An impartial, unconditioned observer would surely record that only the valve and semiconductor boys comprise the true electronics industry, and the rest of us are outsiders with, at best, our noses over the fence. If this is the case, then there is no point in arguing over definitions until we are sure of what we are defining; after all, ours is allegedly a science and as such it should employ exact terminology.

Presumptive Parentage

I humbly submit that "electronics" as a title has no hem to its garment and is the unlawful father of such anachronisms as "Radio and Electronic Manufacturers," "Radar and Electronics" and so on, with which our lives are bestrewn. So, please, let us throw the impostor overboard with a large lump of semiconductor tied to his valency bond and try again with something we can honestly live with.

Perhaps the rather unpleasant truth is that because of our growth we have given ourselves over-many airs. At any rate, we seem curiously reluctant to admit that, when it comes down to brass tacks, we are electrical engineers and that all the multifarious activities which we have classified as "electronics" are only off-shoots from the main stem.

A parallel case exists in medicine, where specialists abound. But between the neurologists and gynaecologists and all the other -ologists made any attempt to find a definitive umbrella under which to shelter? No; they are content to regard themselves as members of the medical profession, and have thereby kept sane. Why, then, should we find it any more essential to set ourselves apart than they? We, too, have our specialist labels for ready identification as occasion demands, and these should surely suffice.

In the event, if we are realistic about the matter, we seem to have no option but to accept the fact that it is virtually impossible to devise a definition which covers each and every one of our activities, much less a single descriptive word. And, as the Editor has pointed out by quoting Professor Everitt, even if the perfect solution were found today it would be outdated by tomorrow. So why bother, except to set our house in order by relegating the expression "electronics" to its rightful place as the specialist label for the valve and semiconductor people, so that for the first time such terms as "Radio and Electronics" make scientific sense.

But if the worst comes to the worst and we still remain too stiff-necked to accept ourselves as specialist electrical engineers, perhaps we might take the opportunity to pay a tribute to one or other of the early researchers who set in motion the chain of events which placed us on our purgatorial path? How, for instance, would you like to be described as a Hertzian engineer? It certainly would evade the "descriptive word" issue but resurrects the definition boggy again.

No, on balance I don't think it's worth it.

*The one I like best is "Electronics. Anything electrical which I don't understand"—Ed.